

REVISIONS

LTR	DESCRIPTION										DATE (YR-MO-DA)				APPROVED			

REV																					
SHEET	35	36	37	38	39	40	41														
REV																					
SHEET	15	16	17	18	19	20	21	22	23	24	25	26	26	28	29	30	31	32	33	34	
REV STATUS OF SHEETS				REV																	
				SHEET				1	2	3	4	5	6	7	8	9	10	11	12	13	14

PMIC N/A	PREPARED BY Kenneth Rice				<p align="center"><b>DEFENSE SUPPLY CENTER COLUMBUS</b>  <b>COLUMBUS, OHIO 43216</b>  <a href="http://www.dsccl.dla.mil">http://www.dsccl.dla.mil</a></p>																
<p align="center"><b>STANDARD MICROCIRCUIT DRAWING</b></p> <p align="center">THIS DRAWING IS AVAILABLE FOR USE BY ALL DEPARTMENTS AND AGENCIES OF THE DEPARTMENT OF DEFENSE</p> <p align="center">AMSC N/A</p>	CHECKED BY Jeff Bowling																				
	APPROVED BY Raymond Monnin																				
	DRAWING APPROVAL DATE 98-11-23																				
	REVISION LEVEL																				
				SIZE <b>A</b>	CAGE CODE <b>67268</b>	<b>5962-98511</b>															
				SHEET 1 OF 41																	

1. SCOPE

1.1 Scope. This drawing documents three product assurance class levels consisting of space application (device class V), high reliability (device classes M and Q), and nontraditional performance environment (device class N). A choice of case outlines and lead finishes are available and are reflected in the Part or Identifying Number (PIN). When available, a choice of Radiation Hardness Assurance (RHA) levels are reflected in the PIN. For device class N, the user is cautioned to assure that the device is appropriate for the application environment.

1.2 PIN. The PIN shall be as shown in the following example:

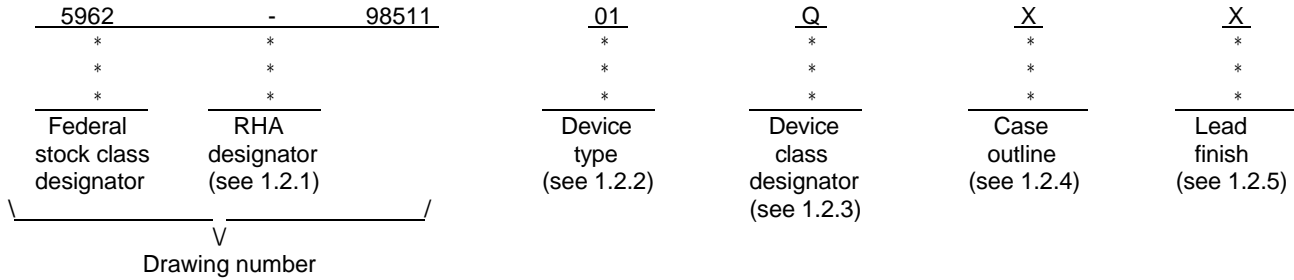

1.2.1 RHA designator. Device classes N, Q, and V RHA marked devices meet the MIL-PRF-38535 specified RHA levels and are marked with the appropriate RHA designator. Device class M RHA marked devices meet the MIL-PRF-38535, appendix A specified RHA levels and are marked with the appropriate RHA designator. A dash (-) indicates a non-RHA device.

1.2.2 Device type(s). The device type(s) shall identify the circuit function as follows:

<u>Device type</u>	<u>Generic number</u>	<u>Circuit function</u>	<u>Access time</u>
01	XQ4062XL-3	62000 gate programmable array	3.0 ns

1.2.3 Device class designator. The device class designator shall be a single letter identifying the product assurance level as follows:

<u>Device class</u>	<u>Device requirements documentation</u>
M	Vendor self-certification to the requirements for MIL-STD-883 compliant, non-JAN class level B microcircuits in accordance with MIL-PRF-38535, appendix A
N	Certification and qualification to MIL-PRF-38535 with a non-traditional performance environment encapsulated in plastic
Q or V	Certification and qualification to MIL-PRF-38535

1.2.4 Case outline(s). The case outline(s) are as designated in MIL-STD-1835, JEDEC Publication 95, and as follows:

<u>Outline letter</u>	<u>Descriptive designator</u>	<u>Terminals</u>	<u>Package style</u>
X	CMGA37-P475	475	Pin grid array package
Y	See figure 1	228	Quad flat package
Z	See figure 1	228	Quad flat package
U	LBGA-B-432 (JEDEC MO-192-BAU-1 )	432	Ball grid array with four rows on each side (plastic)
T	PQFP-G-240 (JEDEC MS-029-GA )	240	Quad flat package with heat sink molded in the package (plastic)

1.2.5 Lead finish. The lead finish is as specified in MIL-PRF-38535 for device classes N, Q, and V or MIL-PRF-38535, appendix A for device class M.

<b>STANDARD MICROCIRCUIT DRAWING DEFENSE SUPPLY CENTER COLUMBUS COLUMBUS, OHIO 42316-5000</b>	<b>SIZE A</b>		<b>5962-98511</b>
		REVISION LEVEL	SHEET <b>2</b>

1.3 Absolute maximum ratings. 1/ 2/

Supply voltage range to ground potential ( $V_{CC}$ )	-----	-0.5 V dc to +4.0 V dc
DC input voltage range ( $V_{IN}$ )	-----	-0.5 V to 5.5V
Voltage applied to three-state output( $V_{TS}$ )	-----	-0.5 V to 5.5V
Lead temperature (soldering, 10 seconds)	-----	+260EC
Power dissipation (PD)	-----	2.0 W
Thermal resistance, junction-to-case ( $1_{JC}$ ):		
Case outline X	-----	See MIL-STD-1835
Case outlines Y, Z	-----	20EC/W 3/
Case outlines U	-----	0.8EC/W 3/
Case outlines T	-----	1.5EC/W 3/
Junction temperature ( $T_J$ ) for ceramic packages	-----	+150EC 4/
Junction temperature ( $T_J$ ) for plastic packages	-----	+125EC 4/
Storage temperature range	-----	-65EC to +150EC

1.4 Recommended operating conditions.

Supply voltage relative to ground( $V_{CC}$ )	-----	+3.0 V dc minimum to +3.6 V dc maximum
Input high voltage ( $V_{IH}$ )	-----	50% of $V_{CC}$ to 5.5 V
Input low voltage ( $V_{IL}$ )	-----	0V to 30% of $V_{CC}$
Maximum input signal transition time ( $t_{IN}$ )	-----	250 ns
Case operating temperature range ( $T_C$ )	-----	-55EC to +125EC
Junction operating temperature range ( $T_J$ )	-----	-55EC to +125EC for Plastic packages

1.5 Digital logic testing for device classes N, Q and V.

Fault coverage measurement of manufacturing logic tests (MIL-STD-883, test method 5012)	-----	99.9 percent
---	-------	--------------

2. APPLICABLE DOCUMENTS

2.1 Government specification, standards, and handbooks. The following specification, standards, and handbooks form a part of this drawing to the extent specified herein. Unless otherwise specified, the issues of these documents are those listed in the issue of the Department of Defense Index of Specifications and Standards (DoDISS) and supplement thereto, cited in the solicitation.

SPECIFICATION

DEPARTMENT OF DEFENSE

MIL-PRF-38535 - Integrated Circuits, Manufacturing, General Specification for.

STANDARDS

DEPARTMENT OF DEFENSE

MIL-STD-883 - Test Method Standard Microcircuits.  
 MIL-STD-973 - Configuration Management.  
 MIL-STD-1835 - Interface Standard For Microcircuit Case Outlines.

HANDBOOKS

DEPARTMENT OF DEFENSE

MIL-HDBK-103 - List of Standard Microcircuit Drawings (SMD's).  
 MIL-HDBK-780 - Standard Microcircuit Drawings.

(Unless otherwise indicated, copies of the specification, standards, and handbooks are available from the Standardization Document Order Desk, 700 Robbins Avenue, Building 4D, Philadelphia, PA 19111-5094.)

- 1/ All voltage values in this drawing are with respect to  $V_{SS}$   
 2/ Stresses above the absolute maximum rating may cause permanent damage to the device. Extended operation at the maximum levels may degrade performance and affect reliability.  
 3/ When a thermal resistance for this case is specified in MIL-STD-1835 that value shall supersede the value indicated herein.  
 4/ Maximum junction temperature shall not be exceeded except for allowable short duration burn-in screening conditions in accordance with method 5004 of MIL-STD-883.

<b>STANDARD                  MICROCIRCUIT DRAWING                  DEFENSE SUPPLY CENTER COLUMBUS                  COLUMBUS, OHIO 42316-5000</b>	SIZE <b>A</b>		<b>5962-98511</b>
		REVISION LEVEL	SHEET <b>3</b>

2.2 Non-Government publications. The following documents form a part of this document to the extent specified herein. Unless otherwise specified, the issues of the documents which are DoD adopted are those listed in the issue of the DODISS cited in the solicitation. Unless otherwise specified, the issues of documents not listed in the DODISS are the issues of the documents cited in the solicitation.

AMERICAN SOCIETY FOR TESTING AND MATERIALS (ASTM)

ASTM Standard F1192-88 - Standard Guide for the Measurement of Single Event Phenomena from Heavy Ion Irradiation of Semiconductor Devices.

(Applications for copies of ASTM publications should be addressed to the American Society for Testing and Materials, 1916 Race Street, Philadelphia, PA 19103.)

ELECTRONICS INDUSTRIES ALLIANCE (EIA)

JEDEC Standard No. 17 - A Standardized Test Procedure for the Characterization of Latch-up in CMOS Integrated Circuits.

JEDEC Publication 95 - Registered and Standard Outlines for Semiconductor Devices

(Applications for copies should be addressed to the Electronics Industries Alliance, 2500 Wilson Blvd., Arlington, VA 22201.

(Non-Government standards and other publications are normally available from the organizations that prepare or distribute the documents. These documents also may be available in or through libraries or other informational services.)

2.3 Order of precedence. In the event of a conflict between the text of this drawing and the references cited herein, the text of this drawing shall take precedence. Nothing in this document, however, supersedes applicable laws and regulations unless a specific exemption has been obtained.

3. REQUIREMENTS

3.1 Item requirements. The individual item requirements for device classes N, Q, and V shall be in accordance with MIL-PRF-38535 and as specified herein or as modified in the device manufacturer's Quality Management (QM) plan. The modification in the QM plan shall not affect the form, fit, or function as described herein. The individual item requirements for device class M shall be in accordance with MIL-PRF-38535, appendix A for non-JAN class level B devices and as specified herein.

3.2 Design, construction, and physical dimensions. The design, construction, and physical dimensions shall be as specified in MIL-PRF-38535 and herein for device classes N, Q, and V or MIL-PRF-38535, appendix A and herein for device class M.

3.2.1 Case outline(s). The case outline(s) shall be in accordance with 1.2.4 herein and figure 1.

3.2.2 Terminal connections. The terminal connections shall be as specified on figure 2.

3.2.3 Logic block diagram. The logic block diagram shall be as specified on figure 3.

3.3 Electrical performance characteristics and postirradiation parameter limits. Unless otherwise specified herein, the electrical performance characteristics and postirradiation parameter limits are as specified in table I and shall apply over the full case operating temperature range.

3.4 Electrical test requirements. The electrical test requirements shall be the subgroups specified in table IIA. The electrical tests for each subgroup are defined in table I.

3.5 Marking. The part shall be marked with the PIN listed in 1.2 herein. In addition, the manufacturer's PIN may also be marked as listed in MIL-HDBK-103. For packages where marking of the entire SMD PIN number is not feasible due to space limitations, the manufacturer has the option of not marking the "5962-" on the device. For RHA product using this option, the RHA designator shall still be marked. Marking for device classes N, Q, and V shall be in accordance with MIL-PRF-38535. Marking for device class M shall be in accordance with MIL-PRF-38535, appendix A.

<b>STANDARD MICROCIRCUIT DRAWING DEFENSE SUPPLY CENTER COLUMBUS COLUMBUS, OHIO 42316-5000</b>	<b>SIZE A</b>		<b>5962-98511</b>
		REVISION LEVEL	SHEET 4

3.5.1 Certification/compliance mark. The certification mark for device classes N, Q, and V shall be a "QML" or "Q" as required in MIL-PRF-38535. The compliance mark for device class M shall be a "C" as required in MIL-PRF-38535, appendix A.

3.6 Certificate of compliance. For device classes N, Q, and V, a certificate of compliance shall be required from a QML-38535 listed manufacturer in order to supply to the requirements of this drawing (see 6.6.1 herein). For device class M, a certificate of compliance shall be required from a manufacturer in order to be listed as an approved source of supply in MIL-HDBK-103 (see 6.6.2 herein). The certificate of compliance submitted to DSCC-VA prior to listing as an approved source of supply for this drawing shall affirm that the manufacturer's product meets, for device classes N, Q, and V, the requirements of MIL-PRF-38535 and herein or for device class M, the requirements of MIL-PRF-38535, appendix A and herein.

3.7 Certificate of conformance. A certificate of conformance as required for device classes N, Q, and V in MIL-PRF-38535 or for device class M in MIL-PRF-38535, appendix A shall be provided with each lot of microcircuits delivered to this drawing.

3.8 Notification of change for device class M. For device class M, notification to DSCC-VA of change of product (see 6.2 herein) involving devices acquired to this drawing is required for any change as defined in MIL-STD-973.

3.9 Verification and review for device class M. For device class M, DSCC, DSCC's agent, and the acquiring activity retain the option to review the manufacturer's facility and applicable required documentation. Offshore documentation shall be made available onshore at the option of the reviewer.

3.10 Microcircuit group assignment for device class M. Device class M devices covered by this drawing shall be in microcircuit group number 42 (see MIL-PRF-38535, appendix A).

4. QUALITY ASSURANCE PROVISIONS

4.1 Sampling and inspection. For device classes N, Q, and V, sampling and inspection procedures shall be in accordance with MIL-PRF-38535 or as modified in the device manufacturer's Quality Management (QM) plan. The modification in the QM plan shall not affect the form, fit, or function as described herein. For device class M, sampling and inspection procedures shall be in accordance with MIL-PRF-38535, appendix A.

4.2 Screening. For device classes N, Q, and V, screening shall be in accordance with MIL-PRF-38535, and shall be conducted on all devices prior to qualification and technology conformance inspection. For device class M, screening shall be in accordance with method 5004 of MIL-STD-883, and shall be conducted on all devices prior to quality conformance inspection.

4.2.1 Additional criteria for device class M.

- a. Delete the sequence specified as initial (preburn-in) electrical parameters through interim (postburn-in) electrical parameters of method 5004 and substitute lines 1 through 6 of table IIA herein.
- b. For device class M, the test circuit shall be maintained by the manufacturer under document revision level control and shall be made available to the preparing or acquiring activity upon request. For device class M, the test circuit shall specify the inputs, outputs, biases, and power dissipation, as applicable, in accordance with the intent specified in test method 1015.
- c. Interim and final electrical parameters shall be as specified in table IIA herein.

4.2.2 Additional criteria for device classes N, Q, and V.

- a. The burn-in test duration, test condition and test temperature, or approved alternatives shall be as specified in the device manufacturer's QM plan in accordance with MIL-PRF-38535. The burn-in test circuit shall be maintained under document revision level control of the device manufacturer's Technology Review Board (TRB) in accordance with MIL-PRF-38535 and shall be made available to the acquiring or preparing activity upon request. The test circuit shall specify the inputs, outputs, biases, and power dissipation, as applicable, in accordance with the intent specified in test method 1015 of MIL-STD-883.
- b. Interim and final electrical test parameters shall be as specified in table IIA herein.
- c. Additional screening for device class V beyond the requirements of device class Q shall be as specified in appendix B of MIL-PRF-38535.

<b>STANDARD MICROCIRCUIT DRAWING DEFENSE SUPPLY CENTER COLUMBUS COLUMBUS, OHIO 42316-5000</b>	<b>SIZE A</b>		<b>5962-98511</b>
		REVISION LEVEL	SHEET 5

TABLE I. Electrical performance characteristics.

Test	Symbol	Conditions 3.0#V <sub>CC</sub> #3.6V (-55EC#T <sub>C</sub> #+125EC for ceramic packages) (-55EC#T <sub>J</sub> #+125EC for plastic packages)	Group A Subgroups	Device Types	Limits		Units	
					Min	Max		
High-level output voltage	VOH	IOH = -4 mA, VCC=min ( LVTTTL )	1, 2, 3	01	2.4		V	
High-level output voltage		IOH = -500 FA, VCC= min (LVCMOS)	1, 2, 3	01	90% VCC		V	
Low-level output voltage	VOL	IOL = 12 mA, VCC=min ( LVTTTL ) 1/	1, 2, 3	01		0.4	V	
Low-level output voltage		IOL = 1500 FA, VCC=min ( LVCMOS)	1, 2, 3	01		10% VCC	V	
Data Retention Supply Voltage ( below which configuration data may be lost)	VDR	(Read back mode only)	1, 2, 3	01	2.5		V	
Quiescent FPGA Supply current 2/	ICCO		1, 2, 3	01		25	mA	
Input or output leakage current	IL		1, 2, 3	01	-10	+10	FA	
Input capacitance (sample tested)	Uand T case outlines  X, Y, Z, case outline	C <sub>IN</sub> , C <sub>OUT</sub>	See 4.4.1e, f = 1.0 Mhz, V <sub>OUT</sub> = 0 V	4	01		10	pf
							16	pf
Pad pull-up ( when selected )	IRPU	VIN = 0V ( sample tested )	1, 2, 3	01	0.02	0.25	mA	
Pad pull-down ( when selected)	IRPD	VIN = 3.6V (sample tested)	1, 2, 3	01	0.02	0.15	mA	
Horizontal Longline pull-up (when selected) @ logic Low	IRLL		1, 2, 3	01	0.3	2.0	mA	
Functional test	FT	See 4.4.1c	7, 8A, 8B	01				

See notes at end of table.

<b>STANDARD MICROCIRCUIT DRAWING DEFENSE SUPPLY CENTER COLUMBUS COLUMBUS, OHIO 42316-5000</b>	<b>SIZE A</b>		<b>5962-98511</b>
		REVISION LEVEL	SHEET <b>6</b>

TABLE I. Electrical performance characteristics.

Test	Symbol	Conditions 3.0#V <sub>CC</sub> #3.6V (-55EC#T <sub>C</sub> #+125EC for ceramic packages) (-55EC#T <sub>J</sub> #+125EC for plastic packages)	Group A Subgroups	Device Types	Limits		Units
					Min	Max	
Wide Decoder Switching Characteristic Guidelines							
Full length, two pull-ups, inputs from IOB I-pins <u>3/</u>	TWAF2	See figure 4 as applicable <u>4/ 5/</u>	9, 10, 11	01		19.6	ns
Half length, two pull-ups, inputs from IOB I-pins <u>3/</u>	TWAO2					11.7	
CLB Switching Characteristic Guidelines							
Combinatorial Delays							
F/G inputs to X/Y outputs	TILO	See figures 3 and 4 as applicable <u>4/ 5/</u>	9, 10, 11	01		1.6	ns
F/G inputs via H' to X/Y outputs	TIHO					2.7	
F/G inputs via transparent latch to Q outputs	TITO	See figures 3 and 4 as applicable <u>6/</u>				2.9	
C inputs via SR/HO via H to X/Y outputs	THH0O	See figures 3 and 4 as applicable <u>4/ 5/</u>				2.5	
C inputs via HI via H to X/Y outputs	THH1O					2.4	
C inputs via DIN/H2 via H to X/Y outputs	THH2O					2.5	
C inputs via EC, DIN/H2 to YQ, XQ output ( bypass )	TCBYP					1.5	
CLB Fast Carry Logic							
Operand inputs ( F1, F2, G1, G4 ) to COUT	TOPCY	See figure 3 as applicable <u>6/</u>	9, 10, 11	01		2.7	ns
Add/Subtract input (F3) to COUT	TASCY	See figure 3 as applicable <u>6/</u>				3.3	
Initialization inputs ( F1,F3 ) to COUT	TINCY	See figure 3 as applicable <u>4/ 5/</u>				2.0	
CIN through function generators to X/Y outputs	TSUM	See figure 3 as applicable <u>4/ 5/</u>				2.8	
CIN to COUT, bypass function generators	TBYP	See figure 3 as applicable <u>6/</u>				0.3	
Sequential Delays							
Clock K to Flip-Flop outputs Q	TCKO	See figures 3 and 4 as applicable <u>4/ 5/</u>	9, 10, 11	01		2.1	ns
Clock K to Latch outputs Q	TCKLO	See figure 3 <u>6/</u>				2.1	
See notes at end of table.							
<b>STANDARD MICROCIRCUIT DRAWING DEFENSE SUPPLY CENTER COLUMBUS COLUMBUS, OHIO 42316-5000</b>			<b>SIZE A</b>		<b>5962-98511</b>		
			REVISION LEVEL		SHEET <b>7</b>		

TABLE I. Electrical performance characteristics.

Test	Symbol	Conditions 3.0#V <sub>CC</sub> #3.6V (-55EC#T <sub>C</sub> #+125EC for ceramic packages) (-55EC#T <sub>J</sub> #+125EC for plastic packages)	Group A Subgroups	Device Types	Limits		Units
					Min	Max	
Setup Time before Clock K							
F/G inputs	TICK	See figure 3 6/	9, 10, 11	01	1.1		ns
F/G inputs via H	TIHCK				2.2		ns
C inputs via H0 through H	THH0CK				2		ns
C inputs via H1 through H	THH1CK				1.9		ns
C inputs via H2 through H	THH2CK				2		ns
C inputs Via DIN	TDICK				0.9		ns
C inputs via EC	TECCK				1		ns
C inputs via S/R, going Low ( inactive )	TRCK				0.6		ns
CIN input via F/G	TCCK				2.3		ns
CIN input via F/G and H	TCHCK				3.4		ns
Hold Time after Clock K							
F/G inputs	TCKI	See figure 3 6/	9, 10, 11		0		ns
F/G inputs via H	TCKIH			0		ns	
C inputs via SR/HO through H	TCKHH0			0		ns	
C inputs via H1 through H	TCKHH1			0		ns	
C inputs via DIN/H2 through H	TCKHH2			0		ns	
C inputs via DIN/H2	TCKDI			0		ns	
C inputs via EC	TCKEC			0		ns	
C inputs via SR, going Low ( inactive )	TCKR			0		ns	

See notes at end of table.

<b>STANDARD MICROCIRCUIT DRAWING DEFENSE SUPPLY CENTER COLUMBUS COLUMBUS, OHIO 42316-5000</b>	<b>SIZE A</b>		<b>5962-98511</b>
		REVISION LEVEL	SHEET <b>8</b>



TABLE I. Electrical performance characteristics.

Test	Symbol	Conditions 3.0#V <sub>cc</sub> #3.6V (-55EC#T <sub>C</sub> #+125EC for ceramic packages) (-55EC#T <sub>J</sub> #+125EC for plastic packages)	Group A Subgroups	Device Types	Limits		Units
					Min	Max	
Clock							
Clock High time	TCH	See figure 3 6/	9, 10, 11	01	3		ns
Clock Low time	TCL				3		ns
Set/Reset Direct (The following table must be used to adjust output parameters and output switching characteristics)							
Width ( High)	TRPW	See figure 3 6/	9, 10, 11	01	3		ns
Delay from C inputs via S/R, going High to Q	TRIO					3.7	ns
Global Set/Reset							
Minimum GSR Pulse Width	TMRW	See figure 3 6/	9, 10, 11	01	19.8		ns
Delay from GSR input to any Q	TMRQ					29.1	ns
Delay from GSR input to any Pad	TRPO					33.7	ns
Toggle Frequency ( MHz ) 7/	FTOG					166	MHz
Propogation Delays							
Clock ( OK ) to Pad	TOKPOF	See figure 3 6/	9, 10, 11	01		5	ns
Output ( O ) to Pad	TOPF					4.1	
3 state to Pad hi-Z ( slew- rate independent )	TTSHZ					4.4	
3-state to Pad active and valid	TTSONF					4.1	
Output (O) to Pad via Fast Output MUX	TOFPF					5.5	
Setup and Hold Times							
Output ( O ) to clock (OK) setup time	TOOK	See figure 3 6/ 8/	9, 10, 11	01	0.5		
Output ( O ) to clock (OK) hold time	TOKO				0		
Clock Enable ( EC ) to clock (OK) setup	TECOK				0		
Clock Enable ( EC ) to clock (OK) hold	TOKEC				0.3		

See notes at end of table.

<b>STANDARD MICROCIRCUIT DRAWING DEFENSE SUPPLY CENTER COLUMBUS COLUMBUS, OHIO 42316-5000</b>	<b>SIZE A</b>		<b>5962-98511</b>
		REVISION LEVEL	SHEET <b>9</b>

TABLE I. Electrical performance characteristics.

Test	Symbol	Conditions 3.0#V <sub>cc</sub> #3.6V (-55EC#T <sub>C</sub> #+125EC for ceramic packages) (-55EC#T <sub>J</sub> #+125EC for plastic packages)	Group A Subgroups	Device Types	Limits		Units
					Min	Max	
Slew Rate Adjustment							
for output SLOW option add	TSLOW	<u>6</u> /	9, 10 11	01		3	ns
BENCHMARK PATTERNS (100% Tested ) Conditions							
Core + TILO+TIHO	TILHO1	See figure 4 as applicable <u>4/ 5/ 9/</u>	9, 10, 11	01		51.1	ns
Core + TILO+TIHO	TILHO2					51.4	
Core + TILO+TIHO	TILHO3					51.3	
Core + TILO+TIHO	TILHO4					51.0	
Core + TILO+TIHO	TILHO5					51.7	
Core + THH0O +THECQO	THH0O					81.5	
Core + THH10 + THH2QO	THH10					84.8	
Core + THH20 + THELQO	THH20					81.2	
Core + TINCY + TSUM	CRY1					53.9	
Local Line Patterns							
Core + Local Line 1	LOCAL 1	See figure 4 as applicable <u>4/ 5/ 9/</u>	9, 10, 11	01		92	ns
Core + Local Line 2	LOCAL 2					101.5	
Core + Local Line 3	LOCAL 3					103.4	
Core + Local Line 4	LOCAL 4					105.7	
Core + Local Line 5	LOCAL 5					112.2	
Core + Local Line 6	LOCAL 6					103.6	
Core + Local Line 7	LOCAL 7					100.8	
Core + Local Line 8	LOCAL 8					96.3	
Core + Local Double Line 1	DBL 1					81	
Core + Local Double Line 2	DBL 2					81.1	
Core + Horizontal Quad A	QHA					125.5	
Core + Horizontal Quad B	QHB					134.2	
Core + Horizontal Quad C	QHC					131.7	
Core + Verticle Quad A	QVA					132.7	
Core + Verticle Quad B	QVB					135.2	
Core + Verticle Quad C	QVC					132.7	

See notes at end of table.

<b>STANDARD MICROCIRCUIT DRAWING DEFENSE SUPPLY CENTER COLUMBUS COLUMBUS, OHIO 42316-5000</b>	<b>SIZE A</b>		<b>5962-98511</b>
		REVISION LEVEL	SHEET <b>10</b>

TABLE I. Electrical performance characteristics.

Test	Symbol	Conditions 3.0#Vcc#3.6V (-55EC#T <sub>C</sub> #+125EC for ceramic packages) (-55EC#T <sub>J</sub> #+125EC for plastic packages)	Group A Subgroups	Device Types	Limits		Units
					Min	Max	
Long-Line patterns							
Core + Horizontal Long Line 1	HLL1	See figure 4 as applicable <u>4/ 5/ 9/</u>	9, 10, 11	01		111.4	ns
Core + Horizontal Long Line 2	HLL2					168.7	
Core + Horizontal Long Line 3	HLL3					160.5	
Core + Horizontal Long Line 4	HLL4					129.4	
Core + Horizontal Long Line 5	HLL5					170.1	
Core + Horizontal Long Line 6	HLL6					174.7	
Core + Vertical Long Line 1	VLL1					75.9	
Core + Vertical Long Line 2	VLL2					81.8	
Core + Vertical Long Line 3	VLL3					84.9	
Core + Vertical Long Line 4	VLL4					83	
Core + Vertical Long Line 5	VLL5					80.3	
Core + Vertical Long Line 6	VLL6					80.8	
Core + Vertical Long Line 7	VLL7					85.9	
Core + Vertical Long Line 8	VLL8					89.5	
Core + Vertical Long Line 9	VLL9					86.6	
Core + Vertical Long Line 10	VLL10					88.5	
Core + Horizontal Long Line 1 ( Loaded )	HLL1_L					206.3	
Core + Horizontal Long Line 2 ( Loaded )	HLL2_L					304.9	
Core + Horizontal Long Line 3 ( Loaded )	HLL3_L					257.9	
Core + Horizontal Long Line 4 ( Loaded )	HLL4_L					209.5	
Core + Horizontal Long Line 5 ( Loaded )	HLL5_L		294.7				
Core + Horizontal Long Line 6 ( Loaded )	HLL6_L		325				

See notes at end of table.

<b>STANDARD MICROCIRCUIT DRAWING DEFENSE SUPPLY CENTER COLUMBUS COLUMBUS, OHIO 42316-5000</b>	<b>SIZE A</b>		<b>5962-98511</b>
		REVISION LEVEL	SHEET <b>11</b>

TABLE I. Electrical performance characteristics.

Test	Symbol	Conditions 3.0#Vcc#3.6V (-55EC#T <sub>C</sub> #+125EC for ceramic packages) (-55EC#T <sub>J</sub> #+125EC for plastic packages)	Group A Subgroups	Device Types	Limits		Units
					Min	Max	
Core + Vertical Long Line 1 ( Loaded )	VLL1_L	See figure 4 as applicable 4/ 5/ 10/	9, 10, 11	01		137.5	ns
Core + Vertical Long Line 2 ( Loaded )	VLL2_L					126.7	
Core + Vertical Long Line 3 ( Loaded )	VLL3_L					127.7	
Core + Vertical Long Line 4 ( Loaded )	VLL4_L					129.9	
Core + Vertical Long Line 5 ( Loaded )	VLL5_L					122.4	
Core + Vertical Long Line 6 ( Loaded )	VLL6_L					114.9	
Core + Vertical Long Line 7 ( Loaded )	VLL7_L					135.4	
Core + Vertical Long Line 8 ( Loaded )	VLL8_L					137.8	
Core + Vertical Long Line 9 ( Loaded )	VLL9_L					108.3	
Core + Vertical Long Line 10 ( Loaded )	VLL10_L					134.2	
Clock Patterns							
Global Low Skew Clock	GLS	See figure 4 as applicable 4/ 5/	9, 10, 11	01		71.4	ns
Global Early Clock	GE					158.8	
KX Clock Line	KX_K					142.7	
Edge Line Patterns							
Core + Edge Long Line	EDGE LL	See figure 4 as applicable. 4/ 5/ and 9/ where applicable)	9, 10, 11	01		192.9	ns
Octal 1	OCTAL 1					96.6	
Core + Top Edge Double Line	T_EDBL					56	
Core + Left Edge Double Line	L_EDBL					50.6	
Core + Bottom Edge Double Line	B_EDBL					55.4	

See notes at end of table.

<b>STANDARD MICROCIRCUIT DRAWING DEFENSE SUPPLY CENTER COLUMBUS COLUMBUS, OHIO 42316-5000</b>	<b>SIZE A</b>		<b>5962-98511</b>
		REVISION LEVEL	SHEET <b>12</b>

TABLE I. Electrical performance characteristics.

Test	Symbol	Conditions 3.0#Vcc#3.6V (-55EC#T <sub>C</sub> #+125EC for ceramic packages) (-55EC#T <sub>J</sub> #+125EC for plastic packages)	Group A Subgroups	Device Types	Limits		Units
					Min	Max	
Core +Right Edge Double Line	R_EDBL	See figure 4 as applicable 4/ 5/ and 9/ where applicable)	9, 10, 11	01		52.3	ns
Top Left Half Wide Decoder	TL_HWD2					84.8	
Top Right Half Wide Decoder	TR_HWD2					205.8	
Full Wide Decoder	R_WD2					153.1	
Buffer Patterns							
Full Length Tbuf at HLL3	F_TBUF3	See figure 4 as applicable 4/ 5/	9, 10, 11	01		551	ns
Full Length Tbuf at HLL4	F_TBUF4					550	
Left Half Length Tbuf at HLL3 with 4 Pullup	L_TBUF3_4					118	
Left Half Length Tbuf at HLL4 with 4 Pullup	L_TBUF4_4					116	
Left Half Length Tbuf at HLL3 with 1 Pullup	L_TBUF3_1					910.1	
Left Half Length Tbuf at HLL4 with 1 Pullup	L_TBUF4_1					908.5	
Right Half Length Tbuf at HLL3 with 4 Pullup	R_TBUF3_4					118	
Right Half Length Tbuf at HLL4 with 4 Pullup	R_TBUF4_4					116	
Right Half Length Tbuf at HLL3 with 1 Pullup	R_TBUF3_1					909.2	
Right Half Length Tbuf at HLL4 with 1 Pullup	R_TBUF4_1					907.4	
Clock/Setup/Hold Patterns							
GLS Clock Setup	SETUP_GLS	See figure 4 as applicable 4/ 5/	9, 10, 11	01	6.6		ns
GE Clock Setup	SETUP_GE				9.0		
GLS Clock Hold	HOLD_GLS				0		
GE Clock Hold	HOLD_GE				1.5		
GE Clock Hold	TCKO_GLS_ POS					11	

See notes at end of table.

<b>STANDARD MICROCIRCUIT DRAWING DEFENSE SUPPLY CENTER COLUMBUS COLUMBUS, OHIO 42316-5000</b>	<b>SIZE A</b>		<b>5962-98511</b>
		REVISION LEVEL	SHEET <b>13</b>

TABLE I. Electrical performance characteristics.

Test	Symbol	Conditions 3.0#Vcc#3.6V (-55EC#T <sub>C</sub> ##+125EC for ceramic packages) (-55EC#T <sub>J</sub> ##+125EC for plastic packages)	Group A Subgroups	Device Types	Limits		Units
					Min	Max	
GLS Clock To Out ( rise )	TCKO_GLS_NEG	See figure 4 as applicable <u>4/ 5/</u>	9, 10, 11	01		11	ns
GLS Clock To Out ( fall )	TCKO_GE_POS					10.4	
GE Clock To Out ( fall )	TCKO_GE_NEG					10.4	
IOB Patterns (CMOS)							
TPPLI To TOPS	TPPLI_TOPS	See figure 4 as applicable <u>4/ 5/</u> and ( <u>10</u> where applicable)	9, 10, 11	01		17.3	ns
TPID To Out Thru MUX1	TPID_TMUX1					7.3	
TPID to TOPF Thru Wide Decoder	TPID_WDEC_TOPF					53.7	
TPLI To Out Thru EC	TPLI_TECI					8.7	
TPPLI To Out Thru EC	TPPLI_TEC					15.7	
TPDLI To TOPF	TPDLI_TOPF					17.7	
TPFLI to TOPF	TPFLI_TOPF					8.8	
TPID To Out Thru MUX0	TPID_TMUXO					7.9	
TPPFLI To TOPF	TPPFLI_TOPF					15	
TPID To TOPF	TPID_TOPF					5.8	
TBUF driving half a Horizontal Longline (Horizontal Longline Switching Characteristics Guidelines)							
I going High or Low to half of a Horizontal Longline going High or Low, while T is Low. Buffer is constantly active.	T HIO1	See figure 4 as applicable <u>4/ 5/ 11/</u>	9, 10, 11	01		5.6	ns
T going Low to half of a Horizontal Longline going from resistive pull-up or floating High to active Low. TBUF configured as open-drain or active buffer with I = Low	T HON					6.2	
T going High to half of a Horizontal Longline going from Low to High, pulled up by four resistors. <u>12/</u>	T HPU4					6.5	
See notes at end of table.							
<b>STANDARD MICROCIRCUIT DRAWING DEFENSE SUPPLY CENTER COLUMBUS COLUMBUS, OHIO 42316-5000</b>			SIZE <b>A</b>		5962-98511		
				REVISION LEVEL	SHEET <b>14</b>		

TABLE I. Electrical performance characteristics.

Test	Symbol	Conditions 3.0#V <sub>CC</sub> #3.6V (-55EC#T <sub>C</sub> #+125EC for ceramic packages) (-55EC#T <sub>J</sub> #+125EC for plastic packages)	Group A Subgroups	Device Types	Limits		Units
					Min	Max	
TBUF driving a Horizontal Longline							
I going High or Low to Horizontal Longline going High or Low, while T is Low. Buffer is constantly active.	T IOI	See figure 4 as applicable <u>4/ 5/</u>	9, 10, 11	01		14.9	ns
T going Low to Horizontal Longline going from resistive pull-up or floating High to active Low. TBUF configured as open-drain or active buffer with I = Low.	T ON					15.6	
T going High to Horizontal Longline going from Low to High, pulled up by two resistors. <u>13/</u>	T PU2					17.9	
Setup Times (IOB Input Switching Characteristic Guidelines)							
Pad to Clock (IK), no delay	TPICK	See figure 3 as applicable <u>6/</u>	9, 10, 11	01	1.7		ns
Pad to Clock (IK), partial delay	TPICKP				8.9		
Pad to Clock (IK), full delay	TPICKD				11.3		
Pad to Clock (IK), via transparent Fast Capture Latch, no delay	TPICKF				2.4		
Pad to Clock (IK), via transparent Fast Capture Latch, partial delay	TPICKFP				9.6		
Pad to Fast Capture Latch Enable (OK), no delay	TPOCK <u>8/</u>				0.7		
Clock Enable (EC) to Clock (IK)	TECIK <u>8/</u>				0.3		
Hold Times							
All Hold times	<u>8/</u>	See figure 3 as applicable <u>6/</u>	9, 10, 11	01	0		ns
See notes at end of table.							
<b>STANDARD MICROCIRCUIT DRAWING DEFENSE SUPPLY CENTER COLUMBUS COLUMBUS, OHIO 42316-5000</b>				<b>SIZE A</b>		<b>5962-98511</b>	
				REVISION LEVEL		SHEET <b>15</b>	

TABLE I. Electrical performance characteristics.

Test	Symbol	Conditions 3.0#V <sub>CC</sub> #3.6V (-55EC#T <sub>C</sub> #+125EC for ceramic packages) (-55EC#T <sub>J</sub> #+125EC for plastic packages)	Group A Subgroups	Device Types	Limits		Units
					Min	Max	
Propagation Delays							
Pad to I1, 12 via transparent FCL and input latch, no delay <u>14/</u>	TPFLI	See figures 3 and 4 as applicable <u>4/ 5/</u>	9, 10, 11	01		3.1	ns
Pad to I1, 12 via transparent FCL and input latch, partial delay <u>14/</u>	TPPFLI				10.2		
Clock (IK) to I1, 12 ( flip flop )	TIKRI	See figures 3 and 4 as applicable <u>6/</u>				1.8	
Clock (IK) to I1, 12 ( latch enable, active Low )	TIKLI				1.9		
FCL Enable (OK) active edge to I1, 12 (via transparent standard input latch ) <u>14/</u>	TOKLI				3.6		
Minimum GSR Pulse Width	TMRW				19.8		
Delay from GSR input to any Q	TRRI				29.1		
Delay from FCL enable (OK) active edge to IFF clock (IK) active edge <u>15/</u>	TOKIK	1.7					
Pad to I1, 12	TPID	See figures 3 and 4 as applicable <u>4/ 5/</u>				1.6	
Pad to I1, 12 via transparent latch, no delay	TPLI				2.6		
Pad to I1, 12 via transparent input latch, partial delay	TPPLI				10.2		
Pad to I1, 12 via transparent input latch, full delay	TPDLI				12.7		

See notes at end of table.

<b>STANDARD MICROCIRCUIT DRAWING DEFENSE SUPPLY CENTER COLUMBUS COLUMBUS, OHIO 42316-5000</b>	<b>SIZE A</b>		<b>5962-98511</b>
		REVISION LEVEL	SHEET <b>16</b>



TABLE I. Electrical performance characteristics.

Test	Symbol	Conditions 3.0#Vcc#3.6V (-55EC#T <sub>C</sub> #+125EC for ceramic packages) (-55EC#T <sub>J</sub> #+125EC for plastic packages)	Group A Subgroups	Device Types	Limits		Units
					Min	Max	
Output Flip-Flop, Clock to Out (Pin to Pin Output parametrics Guidelines)							
Global Low Skew Clock to Output using OFF <u>16/</u>	TICKOF	See figures 3 and 4 as applicable <u>4/ 5/ 17/</u>	9, 10, 11	01		11.3	ns
Global Early Clock to Output using OFF Values are for BUFGE #s 1, 2, 5 and 6. Add 1.4 ns for BUFGE #s 3, 4, 7 and 8 <u>16/ 18/</u>	TICKEOF					9.9	
For output SLOW option add	TSLOW					3.0	
Output/Output Mux/Clock to out							
Global Low Skew Clock to Output using OMUX <u>19/</u>	TPFPF	See figure 3 as applicable <u>6/ 17/</u>				11.4	ns
Global Early Clock to Output using OMUX Values are for BUFGE #s 1, 2, 5 and 6. Add 1.4 ns for BUFGE #s 3, 4, 7 and 8 <u>18/ 19/</u>	TPEFPF					10.0	
For output SLOW option add	TSLOW					3.0	
Global Low Skew Clock, Set-Up and Hold							
Input Setup Time, using Global Low Skew clock and IFF ( full delay ) <u>15/</u>	TPSD	See figure 3 as applicable <u>6/ 9/ 20/</u>	9, 10, 11	01	6.8		ns
Input Hold Time, using Global Low Skew clock and IFF ( full delay ) <u>15/</u>	TPHD				0		
Global Buffers Switching Characteristic Guidelines							
From pad through Global Low Skew buffer, to any clock K	TGLS	See figure 4 as applicable <u>4/ 5/ 21/</u>				6.3	ns
From pad through Global Early buffer, to any clock K in same quadrant	TGE					4.9	
See notes at end of table.							
<b>STANDARD MICROCIRCUIT DRAWING DEFENSE SUPPLY CENTER COLUMBUS COLUMBUS, OHIO 42316-5000</b>				SIZE <b>A</b>	<b>5962-98511</b>		
				REVISION LEVEL			

- 1/ With up to 64 pins simultaneously sinking 12 mA.
- 2/ With no output current loads, no active input or Longline pull-up resistors, all I/O pins tri-stated and floating.
- 3/ These delays are specified from the decoder input to the decoder output. Fewer than the specified number of pull up resistors can be used, if desired. Using fewer pull ups reduces power consumption but increases delays. Use the static timing analyzer to determine delays if fewer pull ups are used.
- 4/ Parameter is not directly tested. Devices are first 100 percent functionally tested. Benchmark timing patterns are then used to determine the compliance of this parameter. Characterization data is taken at initial device introduction, and after any design or process changes which may affect this parameter.
- 5/ Benchmark patterns are used to determine compliance to this parameter.
- 6/ Parameter is not tested but is guaranteed by design through simulation.
- 7/ Maximum flip-flop toggle rate for export control purposes.
- 8/ Input pad setup times and hold times are specified with respect to the internal clock ( IK ). To calculate setup time, Subtract clock delay ( clock pad to IK ) from the specified input pad setup time value, but do not subtract below zero, "Negative" hold time means that the delay in the input data is adequate for the external system hold time to be zero, provided the input clock uses the global signal distribution from pad to IK.
- 9/ Core = TILO + TCKO
- 10/ These delays are specified from the decoder input to the decoder output. For pad-to-pad delays, add the input delay (TPID) output delay ( TOPF or TOPS ) .
- 11/ These values include a minimum load of one output, spaced as far as possible from the active pullup(s). Use the static timing analyzer to determine the delay for each destination.
- 12/ Fewer than the specified number of pullup resistors can be used, if desired. Using fewer pullups reduces the power consumption but increases delays. Use the static analyzer to determine delays if fewer pullups are used.
- 13/ These values are for a minimum load with the driver paced as far as possible from the active pull up(s). Fewer than the specified number of pull up resistors can be used, if desired. Using fewer pull ups reduces power consumption but increases delays. Use the static timing analyzer to determine delays if fewer pull ups are used.
- 14/ FCL = Fast Capture Latch
- 15/ IFF = Input Flip-Flop or Latch
- 16/ OFF = Output Flip Flop
- 17/ These are representative values where one global clock input drives one vertical clock line in each accessible column, and where all accessible IOB and CLB flip-flops are clocked by the global clock net. Output timing is measured at ~50% VCC threshold with 35 pF external capacitive load.
- 18/ BUFGE = Global Early Buffers
- 19/ OMUX = Output MUX
- 20/ Setup time is measured with the fastest route and the lightest load. Use the static timing analyzer to determine the setup time under given design conditions. Hold time is measured using the furthest distance and a reference load of one clock pin per two IOBs. Use the static timing analyzer to determine the setup and hold time under given design conditions .
- 21/ Parameters are for BUFGE # 1, 2, 5 and 6. Add 1.4 ns for BUFGE # 3, 4, 7 and 8.

<b>STANDARD MICROCIRCUIT DRAWING DEFENSE SUPPLY CENTER COLUMBUS COLUMBUS, OHIO 42316-5000</b>	<b>SIZE A</b>		<b>5962-98511</b>
		REVISION LEVEL	SHEET <b>18</b>

Cases Y and Z

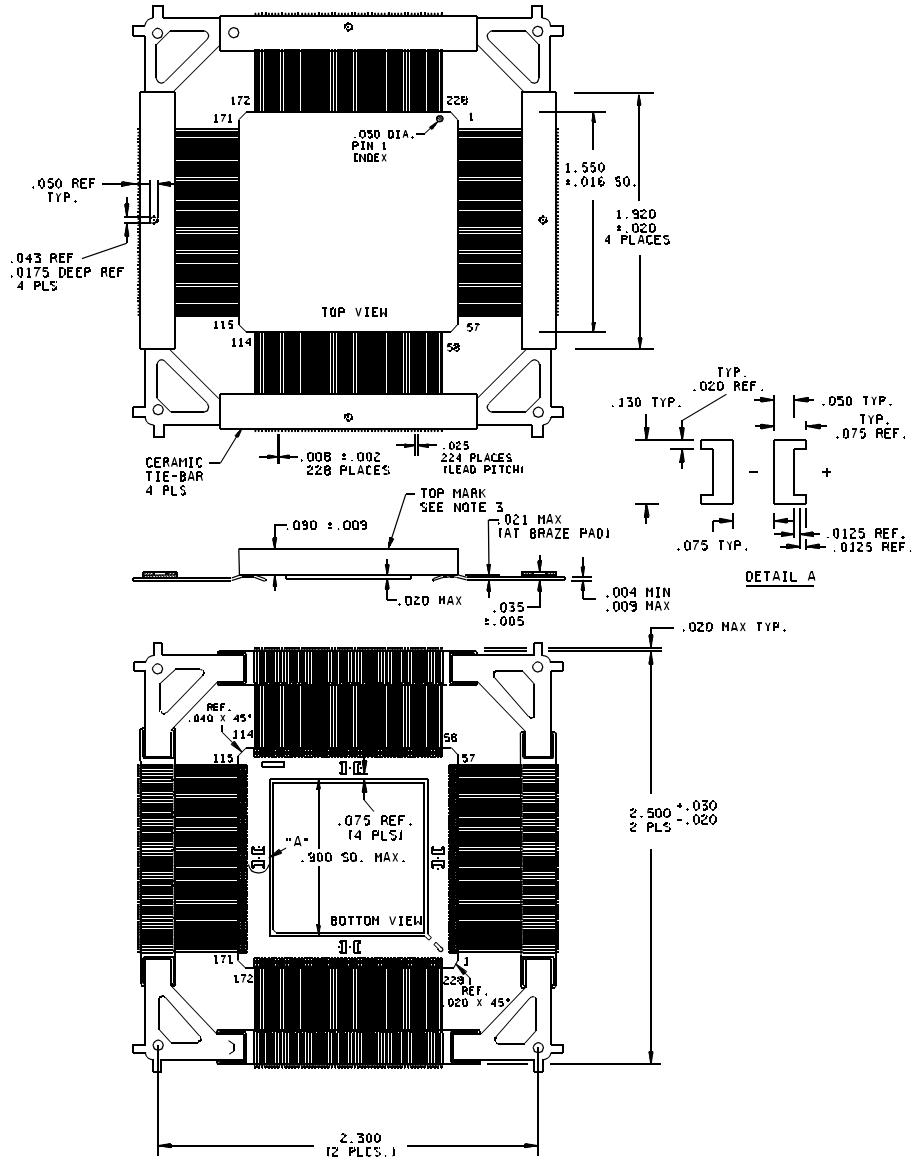

NOTES:

1. Dimensions are in inches.
2. Packages are shipped flat as depicted
3. Lead dimensions call out includes lead finish.
4. The leads of this package style shall be protected from mechanical distortion and damage such that dimensions pertaining to relative lead/body "true positions" and lead "coplanarity" are always maintained until the next higher level package attachment process is complete. Package lead protection mechanisms (tie bars) are shown on the drawing for reference only. When microcircuit devices contained in this package style are shipped for use in Government equipment, or shipped directly to the Government as spare parts or mechanical qualification samples, lead "true position" and "coplanarity" protection shall be in place.
5. Case Y represents marking the device on the nonlid side of device, i.e., lid side facing down. When mounted in this position, the pin out is clockwise. Case Z represents marking the device on the lid side of the device i.e., lid side facing up. When mounted in this position, the pin out is counterclockwise.

FIGURE 1. Case outline.

<b>STANDARD MICROCIRCUIT DRAWING DEFENSE SUPPLY CENTER COLUMBUS COLUMBUS, OHIO 42316-5000</b>	<b>SIZE A</b>		<b>5962-98511</b>
		REVISION LEVEL	SHEET <b>19</b>

Cases Y and Z - Continued

Inch to metric conversion table for convenience only.

Inches	Metric mm
2.500	63.50
2.300	58.42
1.920	48.77
1.550	39.37
.900	22.86
.130	3.30
.125	3.18
.090	2.29
.075	1.91
.050	1.27
.043	1.09
.040	1.02
.035	.89
.030	.76
.025	.64
.021	.53
.020	.51
.0175	.44
.016	.41
.0125	.32
.009	.23
.008	.20
.005	.13
.004	.10
.002	.05

FIGURE 1. Case outline - Continued.

<b>STANDARD MICROCIRCUIT DRAWING DEFENSE SUPPLY CENTER COLUMBUS COLUMBUS, OHIO 42316-5000</b>	<b>SIZE A</b>		<b>5962-98511</b>
		REVISION LEVEL	SHEET <b>20</b>

Case U

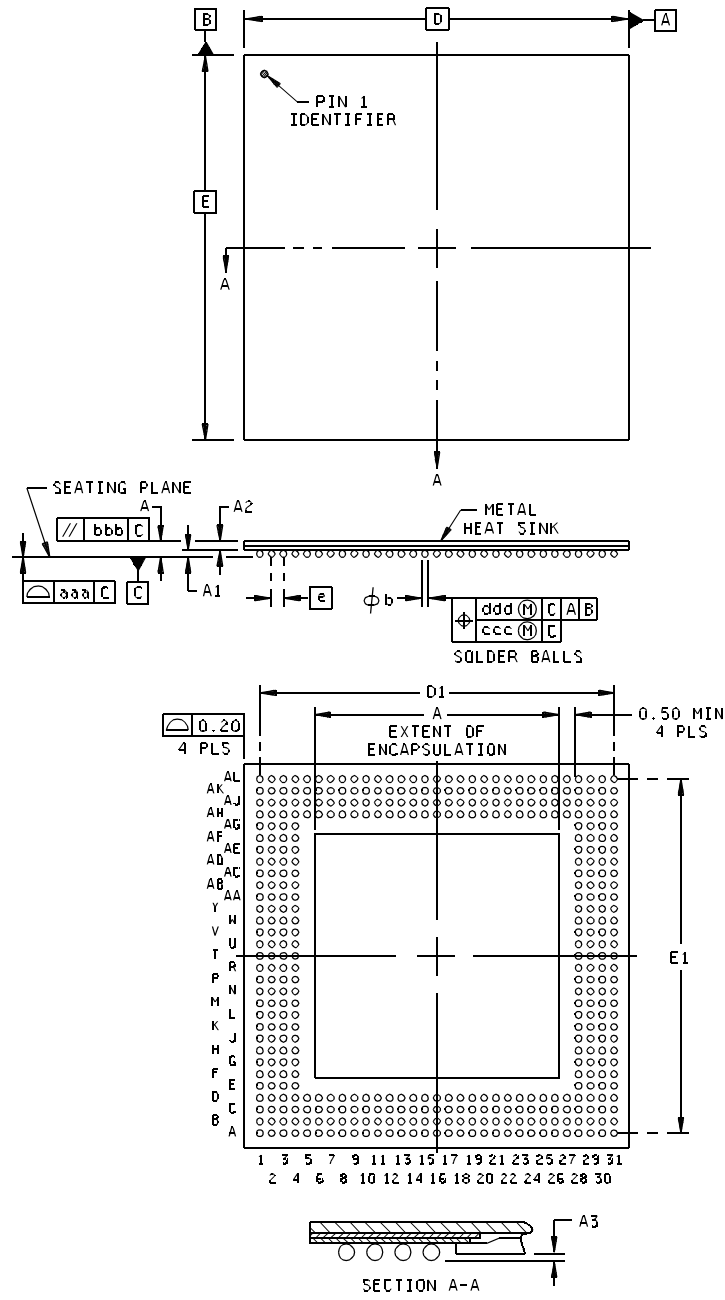

FIGURE 1. Case outline - Continued.

<b>STANDARD MICROCIRCUIT DRAWING DEFENSE SUPPLY CENTER COLUMBUS COLUMBUS, OHIO 42316-5000</b>	<b>SIZE A</b>		<b>5962-98511</b>
		REVISION LEVEL	SHEET <b>21</b>

Case U - Continued.

BG432			
Symbol	Millimeters		
	Min.	Nom.	Max.
A	1.10	1.40	1.70
A1	0.50	0.60	0.70
A2	0.60	---	1.00
A3	0.20	---	---
D/E	40.00 BSC		
D1/E1	38.10 REF		
e	1.27 BSC		
i b	0.60	0.75	0.90
aaa	---	---	0.20
bbb	---	---	0.25
ccc	---	---	0.15
ddd	---	---	0.30
M	31		
REF	JEDEC MO-192-BAU-1		

Notes:

1. All dimensions and tolerances conform to ANSI Y14.5M-1994.
2. Symbol "M" is the pin matrix size.
3. Conforms to JEDEC MO-192 (Depopulated).

FIGURE 1. Case outline - Continued.

<b>STANDARD MICROCIRCUIT DRAWING DEFENSE SUPPLY CENTER COLUMBUS COLUMBUS, OHIO 42316-5000</b>	<b>SIZE A</b>		<b>5962-98511</b>
		REVISION LEVEL	SHEET <b>22</b>

Device type	All	Device type	All	Device type	All
Case outline	X	Case outline	X	Case outline	X
Terminal number	Terminal symbol	Terminal number	Terminal symbol	Terminal number	Terminal symbol
A3	GND	C19	I/O	E33	I/O
A5	I/O	C21	I/O	E35	M0
A7	I/O	C23	I/O	E37	GND
A9	I/O	C25	I/O	E39	GND
A11	I/O	C27	I/O	E41	I/O
A13	I/O	C29	I/O	F2	I/O
A15	I/O	C31	I/O	F4	I/O
A17	GND	C33	I/O	F6	VCC
A19	I/O	C35	GND	F8	TCK_I/O
A21	I/O	C37	I/O	F10	GND
A23	I/O	C39	I/O	F12	I/O
A25	GND	C41	<del>I/O</del>	F14	I/O
A27	I/O	D2	VCC	F16	I/O
A29	I/O_FCLK2	D4	A17_I/O	F18	I/O
A31	GND	D6	TDI_I/O	F20	I/O
A33	I/O	D8	I/O	F22	I/O
A35	I/O	D10	I/O	F24	I/O
A37	VCC	D12	I/O	F26	I/O
A39	M1	D14	I/O	F28	I/O
A41	GND	D16	I/O	F30	I/O
B2	VCC	D18	I/O	F32	GND
B4	I/O	D20	I/O	F34	I/O
B6	I/O	D22	I/O	F36	VCC
B8	I/O	D24	I/O	F38	BUFGS_BL_
B10	I/O	D26	I/O		GCK2_I/O
B12	I/O_FCLK1	D28	I/O	F40	I/O
B14	I/O	D30	I/O	G1	A13_I/O
B16	VCC	D32	I/O	G3	GND
B18	I/O	D34	I/O	G5	I/O
B20	I/O	D36	I/O	G7	BUFGP_TL_
B22	I/O	D38	I/O		A16_GCK1_I/O
B24	I/O	D40	I/O	G9	I/O
B26	VCC	E1	I/O	G11	I/O
B28	I/O	E3	A14_I/O	G13	VCC
B30	I/O	E5	BUFGS_TL_GCK8_	G15	I/O
B32	I/O		A15_I/O	G17	I/O
B34	I/O	E7	I/O	G19	I/O
B36	I/O	E9	I/O	G21	GND
B38	I/O	E11	I/O	G23	I/O
B40	VCC	E13	I/O	G25	I/O
C1	GND	E15	GND	G27	I/O
C3	I/O	E17	I/O	G29	VCC
C5	I/O	E19	I/O	G31	I/O
C7	GND	E21	VCC	G33	M2
C9	I/O	E23	I/O	G35	HDC_I/O
C11	I/O	E25	I/O	G37	I/O
C13	TMS_I/O	E27	GND	G39	GND
C15	I/O	E29	I/O	G41	I/O
C17	I/O	E31	I/O		

FIGURE 2. Terminal connections.

<b>STANDARD MICROCIRCUIT DRAWING DEFENSE SUPPLY CENTER COLUMBUS COLUMBUS, OHIO 42316-5000</b>	<b>SIZE A</b>		<b>5962-98511</b>
		REVISION LEVEL	SHEET <b>23</b>

Device type	All	Device type	All	Device type	All
Case outline	X	Case outline	X	Case outline	X
Terminal number	Terminal symbol	Terminal number	Terminal symbol	Terminal number	Terminal symbol
H2	A12_I/O	R1	I/O	AB2	I/O
H4	I/O	R3	I/O	AB4	A6_I/O
H6	I/O	R5	I/O	AB6	I/O
H36	I/O	R7	I/O	AB36	I/O
H38	I/O	R35	I/O	AB38	I/O
H40	I/O	R37	I/O	AB40	I/O
J1	I/O	R39	I/O	AC1	I/O
J3	I/O	R41	I/O	AC3	I/O
J5	I/O	T2	VCC	AC5	I/O
J7	GND	T4	I/O	AC7	A20_I/O
J35	I/O	T6	I/O	AC35	I/O
J37	BUFGP_BL_	T36	I/O	AC37	I/O
	GCK3_I/O	T38	I/O	AC39	I/O
J39	I/O	T40	VCC	AC41	I/O
J41	I/O	U1	GND	AD2	A21_I/O
K2	I/O	U3	I/O	AD4	A5_I/O
K4	I/O	U5	A18_I/O	AD6	A4_I/O
K6	I/O	U7	I/O	AD36	I/O
K36	I/O	U35	I/O	AD38	I/O
K38	I/O	U37	I/O	AD40	I/O
K40	I/O	U39	I/O	AE1	GND
L1	GND	U41	GND	AE3	I/O
L3	I/O	V2	A10_I/O	AE5	I/O
L5	I/O	V4	A11_I/O	AE7	I/O
L7	I/O	V6	I/O	AE35	I/O
L35	I/O	V36	I/O	AE37	I/O
L37	I/O	V38	I/O	AE39	I/O
L39	I/O	V40	I/O	AE41	GND
L41	GND	W1	A19_I/O	AF2	VCC
M2	I/O	W3	I/O	AF4	I/O
M4	I/O	W5	I/O	AF6	I/O
M6	I/O	W7	I/O	AF36	I/O
M36	I/O	W35	I/O	AF38	I/O
M38	I/O	W37	I/O	AF40	VCC
M40	I/O	W39	I/O	AG1	I/O
N1	I/O	W41	I/O	AG3	I/O
N3	I/O	Y2	A8_I/O	AG5	I/O
N5	I/O	Y4	A9_I/O	AG7	I/O
N7	VCC	Y6	I/O	AG35	I/O
N35	VCC	Y36	I/O	AG37	I/O
N37	I/O	Y38	<del>A18_I/O</del>	AG39	I/O
N39	I/O	Y40	I/O	AG41	I/O
N41	I/O	AA1	VCC	AH2	I/O
P2	I/O	AA3	A7_I/O	AH4	I/O
P4	I/O	AA5	VCC	AH6	GND
P6	GND	AA7	GND	AH36	GND
P36	GND	AA35	GND	AH38	I/O
P38	I/O	AA37	VCC	AH40	I/O
P40	I/O	AA39	I/O		
		AA41	VCC		

FIGURE 2. Terminal connections - Continued.

<b>STANDARD MICROCIRCUIT DRAWING DEFENSE SUPPLY CENTER COLUMBUS COLUMBUS, OHIO 42316-5000</b>	<b>SIZE A</b>		<b>5962-98511</b>
		REVISION LEVEL	SHEET <b>24</b>



Device type	All	Device type	All	Device type	All
Case outline	X	Case outline	X	Case outline	X
Terminal number	Terminal symbol	Terminal number	Terminal symbol	Terminal number	Terminal symbol
AJ1	I/O	AR15	I/O	AU31	I/O
AJ3	I/O	AR17	I/O	AU33	I/O
AJ5	I/O	AR19	I/O	AU35	D7_I/O
AJ7	VCC	AR21	GND	AU37	I/O
AJ35	VCC	AR23	I/O	AU39	BUFGS_BR_ GCK4_I/O
AJ37	I/O	AR25	I/O	AU41	I/O
AJ39	I/O	AR27	I/O	AV2	I/O
AJ41	I/O	AR29	VCC	AV4	I/O
AK2	I/O	AR31	I/O	AV6	BUFGS_TR_GCK6_ DOUT_I/O
AK4	I/O	AR33	I/O	AV8	D1_I/O
AK6	I/O	AR35	DONE	AV10	I/O
AK36	I/O	AR37	I/O	AV12	I/O
AK38	I/O	AR39	GND	AV14	I/O
AK40	I/O	AR41	I/O	AV16	I/O
AL1	GND	AT2	I/O	AV18	I/O
AL3	I/O	AT4	I/O	AV20	I/O
AL5	I/O	AT6	VCC	AV22	I/O
AL7	I/O	AT8	I/O	AV24	I/O
AL35	I/O	AT10	GND	AV26	I/O
AL37	I/O	AT12	I/O	AV28	I/O
AL39	I/O	AT14	I/O	AV30	I/O
AL41	GND	AT16	I/O	AV32	I/O
AM2	I/O	AT18	I/O	AV34	D6_I/O
AM4	I/O	AT20	GND	AV36	I/O
AM6	A3_I/O	AT22	VCC	AV38	BUFGP_BR_GCK5_I/O
AM36	I/O	AT24	I/O	AV40	I/O
AM38	I/O	AT26	I/O	AW1	I/O
AM40	I/O	AT28	I/O	AW3	BUFGP_TR_ GCK7_A1_I/O
AN1	I/O	AT30	I/O	AW5	I/O
AN3	I/O	AT32	GND	AW7	GND
AN5	I/O	AT34	I/O	AW9	I/O
AN7	TDO	AT36	VCC	AW11	I/O
AN35	<del>BR06</del>	AT38	I/O	AW13	I/O
AN37	I/O	AT40	I/O	AW15	D2_I/O
AN39	I/O	AU1	CSI_A2_I/O	AW17	I/O
AN41	I/O	AU3	I/O	AW19	I/O
AP2	I/O	AU5	D0_DIN_I/O	AW21	D3_I/O
AP4	GND	AU7	GND	AW23	I/O
AP6	I/O	AU9	I/O	AW25	I/O
AP36	I/O	AU11	I/O	AW27	I/O
AP38	I/O	AU13	I/O	AW29	I/O
AP40	I/O	AU15	GND	AW31	I/O
AR1	I/O	AU17	I/O	AW33	I/O
AR3	GND	AU19	I/O	AW35	GND
AR5	CCLK	AU21	VCC	AW37	VCC
AR7	A0_W8_I/O	AU23	I/O	AW39	I/O
AR9	I/O	AU25	I/O	AW41	VCC
AR11	I/O	AU27	GND		
AR13	VCC	AU29	I/O		

FIGURE 2. Terminal connections.

<b>STANDARD MICROCIRCUIT DRAWING DEFENSE SUPPLY CENTER COLUMBUS COLUMBUS, OHIO 42316-5000</b>	<b>SIZE A</b>		<b>5962-98511</b>
		REVISION LEVEL	SHEET <b>25</b>

Device type	All	Device type	All	Device type	All
Case outline	X	Case outline	X	Case outline	X
Terminal number	Terminal symbol	Terminal number	Terminal symbol	Terminal number	Terminal symbol
AY2	VCC	AY28	<del>CS0</del> _I/O	BA15	I/O
AY4	I/O	AY30	I/O_FCLK3	BA17	GND
AY6	RDY_ <del>CS0</del> <del>_RCLK</del>	AY32	I/O	BA19	I/O
	_I/O	AY34	I/O	BA21	<del>CS</del> _I/O
AY8	I/O	AY36	I/O	BA23	I/O
AY10	I/O	AY38	I/O	BA25	GND
AY12	I/O	AY40	VCC	BA27	I/O
AY14	I/O	BA1	GND	BA29	D5_I/O
AY16	VCC	BA3	VCC	BA31	I/O
AY18	I/O	BA5	I/O	BA33	I/O
AY20	I/O	BA7	I/O	BA35	I/O
AY22	D4_I/O	BA9	I/O	BA37	I/O
AY24	I/O	BA11	I/O	BA39	I/O
AY26	VCC	BA13	I/O_FCLK4	BA41	GND

FIGURE 2. Terminal connections.

<b>STANDARD MICROCIRCUIT DRAWING DEFENSE SUPPLY CENTER COLUMBUS COLUMBUS, OHIO 42316-5000</b>	<b>SIZE A</b>		<b>5962-98511</b>
		REVISION LEVEL	SHEET <b>26</b>

Case outlines Y and Z

Device type	All	Device type	All	Device type	All
Terminal number	Terminal symbol	Terminal number	Terminal symbol	Terminal number	Terminal symbol
1	VSS	51	I/O	101	I/O
2	BUFGP_TL_A16_GCK1_I/O	52	I/O	102	I/O
3	A17_I/O	53	I/O	103	I/O
4	I/O	54	BUFGS_BL_GCK2_I/O	104	I/O
5	I/O	55	M1	105	I/O
6	TDI_I/O	56	VSS	106	I/O
7	TCK_I/O	57	M0	107	I/O
8	I/O	58	VCC	108	I/O
9	I/O	59	M2	109	I/O
10	I/O	60	BUFGP_BL_GCK3_I/O	110	I/O
11	I/O	61	HDC_I/O	111	I/O
12	I/O	62	I/O	112	BUFGS_BR_GCK4_I/O
13	I/O	63	I/O	113	VSS
14	VSS	64	I/O	114	DONE
15	I/O_FCLK1	65	<del>RDG</del> I/O	115	VCC
16	I/O	66	I/O	116	<del>RR00</del>
17	TMS_I/O	67	I/O	117	D7_I/O
18	I/O	68	I/O	118	BUFGP_BR_GCK5_I/O
19	I/O	69	I/O	119	I/O
20	I/O	70	I/O	120	I/O
21	I/O	71	I/O	121	I/O
22	I/O	72	VSS	122	I/O
23	I/O	73	I/O	123	D6_I/O
24	I/O	74	I/O	124	I/O
25	I/O	75	I/O	125	I/O
26	I/O	76	I/O	126	I/O
27	VSS	77	I/O	127	I/O
28	VCC	78	I/O	128	I/O
29	I/O	79	I/O	129	VSS
30	I/O	80	I/O	130	I/O
31	I/O	81	I/O	131	I/O
32	I/O	82	I/O	132	I/O_FCLK3
33	I/O	83	I/O	133	I/O
34	I/O	84	<del>RDG</del> I/O	134	D5_I/O
35	I/O	85	VCC	135	<del>RR0</del> I/O
36	I/O	86	VSS	136	I/O
37	VCC	87	I/O	137	I/O
38	I/O	88	I/O	138	I/O
39	I/O	89	I/O	139	I/O
40	I/O	90	I/O	140	D4_I/O
41	I/O_FCLK2	91	I/O	141	I/O
42	VSS	92	I/O	142	VCC
43	I/O	93	I/O	143	VSS
44	I/O	94	I/O	144	D3_I/O
45	I/O	95	VCC	145	<del>RR</del> I/O
46	I/O	96	I/O	146	I/O
47	I/O	97	I/O	147	I/O
48	I/O	98	I/O	148	I/O
49	I/O	99	I/O	149	I/O
50	I/O	100	VSS	150	D2_I/O

FIGURE 2. Terminal connections.

<b>STANDARD MICROCIRCUIT DRAWING DEFENSE SUPPLY CENTER COLUMBUS COLUMBUS, OHIO 42316-5000</b>	<b>SIZE A</b>		<b>5962-98511</b>
		REVISION LEVEL	SHEET <b>27</b>

Case outlines Y and Z Continued.

Device type	All	Device type	All	Device type	All
Terminal number	Terminal symbol	Terminal number	Terminal symbol	Terminal number	Terminal symbol
151	I/O	177	I/O	203	A9_I/O
152	VCC	178	CSI_A2_I/O	204	A19_I/O
153	I/O	179	A3_I/O	205	A18_I/O
154	I/O_FCLK4	180	I/O	206	I/O
155	I/O	181	I/O	207	I/O
156	I/O	182	I/O	208	A10_I/O
157	VSS	183	I/O	209	A11_I/O
158	I/O	184	I/O	210	VCC
159	I/O	185	I/O	211	I/O
160	I/O	186	VSS	212	I/O
161	I/O	187	I/O	213	I/O
162	I/O	188	I/O	214	I/O
163	I/O	189	I/O	215	VSS
164	D1_I/O	190	I/O	216	I/O
165	RDY_BUSY_RCLK_I/O	191	VCC	217	I/O
166	I/O	192	A4_I/O	218	I/O
167	I/O	193	A5_I/O	219	I/O
168	D0_DIN_I/O	194	I/O	220	A12_I/O
169	BUFGS_TR_GCK6_DOUT_I/O	195	I/O	221	A13_I/O
170	CCLK	196	A21_I/O	222	I/O
171	VCC	197	A20_I/O	223	I/O
172	TDO	198	A6_I/O	224	I/O
173	VSS	199	A7_I/O	225	I/O
174	A0_W8_I/O	200	VSS	226	A14_I/O
175	BUFGP_TR_GCK7_A1_I/O	201	VCC	227	BUFGS_TL_GCK8_A15_I/O
176	I/O	202	A8_I/O	228	VCC

FIGURE 2. Terminal connections - Continued.

<b>STANDARD MICROCIRCUIT DRAWING DEFENSE SUPPLY CENTER COLUMBUS COLUMBUS, OHIO 42316-5000</b>	<b>SIZE A</b>		<b>5962-98511</b>
		REVISION LEVEL	SHEET <b>28</b>

Device type	All	Device type	All	Device type	All
Case outline	U	Case outline	U	Case outline	U
Terminal number	Terminal symbol	Terminal number	Terminal symbol	Terminal number	Terminal symbol
A1	VCC	B26	A13_I/O	D18	A18_I/O
A2	GND	B27	I/O	D19	I/O
A3	GND	B28	I/O	D20	I/O
A4	I/O	B29	I/O	D21	VCC
A5	CSI_A2_I/O	B30	GND	D22	I/O
A6	I/O	B31	GND	D23	I/O
A7	GND	C1	GND	D24	A12_I/O
A8	I/O	C2	D0_DIN_I/O	D25	I/O
A9	GND	C3	VCC	D26	I/O
A10	I/O	C4	TDO	D27	I/O
A11	VCC	C5	I/O	D28	BUFGS_TL_
A12	I/O	C6	I/O	D29	GCK8_A15_I/O
A13	A5_I/O	C7	I/O		BUFGR_TL_
A14	GND	C8	NC		GCK1_A16_I/O
A15	I/O	C9	I/O	D30	TDI_I/O
A16	A7_I/O	C10	I/O	D31	TCK_I/O
A17	A9_I/O	C11	I/O	E1	I/O
A18	GND	C12	I/O	E2	I/O
A19	I/O	C13	I/O	E3	I/O
A20	I/O	C14	A4_I/O	E4	I/O
A21	VCC	C15	A21_I/O	E28	I/O
A22	I/O	C16	I/O	E29	I/O
A23	GND	C17	I/O	E30	I/O
A24	I/O	C18	A19_I/O	E31	I/O
A25	GND	C19	A11_I/O	F1	I/O
A26	I/O	C20	I/O	F2	RDY_BUS_
A27	I/O	C21	I/O		RC&K_I/O
A28	I/O	C22	I/O	F3	I/O
A29	GND	C23	I/O	F4	I/O
A30	GND	C24	I/O	F28	I/O
A31	VCC	C25	I/O	F29	I/O
B1	GND	C26	I/O	F30	I/O
B2	GND	C27	I/O	F31	I/O
B3	A0_WS_I/O	C28	A14_I/O	G1	GND
B4	I/O	C29	VCC	G2	I/O
B5	I/O	C30	A17_I/O	G3	I/O
B6	I/O	C31	GND	G4	D1_I/O
B7	I/O	D1	I/O	G28	I/O
B8	I/O	D2	I/O	G29	I/O
B9	I/O	D3	BUFGS_TR_GCK6	G30	I/O
B10	I/O		_DOUT_I/O	G31	GND
B11	I/O	D4	CCLK	H1	I/O
B12	I/O	D5	BUFGR_TR_GCK7	H2	I/O
B13	I/O		_A1_I/O	H3	I/O
B14	I/O	D6	I/O	H4	I/O
B15	A20_I/O	D7	A3_I/O	H28	I/O
B16	A6_I/O	D8	I/O	H29	I/O
B17	I/O	D9	I/O	H30	I/O
B18	I/O	D10	I/O	H31	I/O
B19	A10_I/O	D11	VCC	J1	GND
B20	I/O	D12	I/O	J2	I/O
B21	I/O	D13	I/O	J3	I/O
B22	I/O	D14	I/O	J4	I/O
B23	I/O	D15	I/O	J28	I/O
B24	I/O	D16	GND	J29	I/O
B25	I/O	D17	A8_I/O	J31	GND
				K1	I/O

FIGURE 2. Terminal connections - Continued.

<b>STANDARD MICROCIRCUIT DRAWING DEFENSE SUPPLY CENTER COLUMBUS COLUMBUS, OHIO 42316-5000</b>	<b>SIZE A</b>		<b>5962-98511</b>
		REVISION LEVEL	SHEET <b>29</b>

Device type	All	Device type	All	Device type	All
Case outline	U	Case outline	U	Case outline	U
Terminal number	Terminal symbol	Terminal number	Terminal symbol	Terminal number	Terminal symbol
K2	I/O_FCLK4	T29	I/O	AC2	I/O
K3	I/O	T30	I/O	AC3	I/O
K4	I/O	T31	I/O	AC4	I/O
K28	I/O_FCLK1	U1	I/O	AC28	I/O
K29	I/O	U2	I/O	AC29	I/O
K30	TMS_I/O	U3	I/O	AC30	I/O
K31	I/O	U4	I/O	AC31	GND
L1	VCC	U28	I/O	AD1	I/O
L2	D2_I/O	U29	I/O	AD2	I/O
L3	I/O	U30	I/O	AD3	I/O
L4	VCC	U31	I/O	AD4	I/O
L28	VCC	V1	GND	AD28	I/O
L29	I/O	V2	I/O	AD29	I/O
L30	I/O	V3	I/O	AD30	I/O
L31	VCC	V4	I/O	AD31	I/O
M1	I/O	V28	I/O	AE1	GND
M2	I/O	V29	I/O	AE2	I/O
M3	I/O	V30	I/O	AE3	I/O
M4	I/O	V31	GND	AE4	I/O
M28	I/O	W1	I/O	AE28	I/O
M29	I/O	W2	I/O	AE29	I/O
M30	I/O	W3	I/O	AE30	I/O
M31	I/O	W4	I/O	AE31	GND
N1	I/O	W28	I/O	AF1	D6_I/O
N2	I/O	W29	I/O	AF2	I/O
N3	I/O	W30	I/O	AF3	I/O
N4	I/O	W31	I/O	AF4	I/O
N28	I/O	Y1	I/O	AF28	I/O
N29	I/O	Y2	<del>GND</del> I/O	AF29	I/O
N30	I/O	Y3	I/O	AF30	I/O
N31	I/O	Y4	I/O	AF31	I/O
P1	GND	Y28	I/O	AG1	I/O
P2	I/O	Y29	I/O	AG2	I/O
P3	I/O	Y30	I/O	AG3	I/O
P4	I/O	Y31	I/O	AG4	BUFGP_BR_ GCK5_I/O
P28	I/O	AA1	VCC	AG28	I/O
P29	I/O	AA2	D5_I/O	AG29	I/O
P30	I/O	AA3	I/O	AG30	I/O
P31	GND	AA4	VCC	AG31	I/O
R1	<del>R8</del> I/O	AA28	VCC	AH1	I/O
R2	I/O	AA29	I/O	AH2	I/O
R3	I/O	AA30	I/O	AH3	<del>BR06</del>
R4	I/O	AA31	VCC	AH4	DONE
R28	I/O	AB1	I/O_FCLK3	AH5	I/O
R29	I/O	AB2	I/O	AH6	I/O
R30	I/O	AB3	I/O	AH7	I/O
R31	I/O	AB4	I/O	AH8	I/O
T1	D4_I/O	AB28	I/O	AH9	I/O
T2	I/O	AB29	I/O_FCLK2	AH10	I/O
T3	D3_I/O	AB30	I/O	AH11	VCC
T4	GND	AB31	I/O	AH12	I/O
T28	GND	AC1	GND		

FIGURE 2. Terminal connections - Continued.

<b>STANDARD MICROCIRCUIT DRAWING DEFENSE SUPPLY CENTER COLUMBUS COLUMBUS, OHIO 42316-5000</b>	<b>SIZE A</b>		<b>5962-98511</b>
		REVISION LEVEL	SHEET <b>30</b>

Device type	All	Device type	All	Device type	All
Case outline	U	Case outline	U	Case outline	U
Terminal number	Terminal symbol	Terminal number	Terminal symbol	Terminal number	Terminal symbol
AH13	I/O	AJ21	I/O	AK29	BUFGP_BL_
AH14	I/O	AJ22	I/O		GCK3_I/O
AH15	I/O	AJ23	I/O	AK30	GND
AH16	GND	AJ24	I/O	AK31	GND
AH17	I/O	AJ25	I/O	AL1	VCC
AH18	I/O	AJ26	I/O	AL2	GND
AH19	I/O	AJ27	I/O	AL3	GND
AH20	I/O	AJ28	M2	AL4	I/O
AH21	VCC	AJ29	VCC	AL5	I/O
AH22	I/O	AJ30	BUFGS_BL_	AL6	I/O
AH23	I/O		GCK2_I/O	AL7	GND
AH24	I/O	AJ31	GND	AL8	I/O
AH25	I/O	AK1	GND	AL9	GND
AH26	<del>BB</del> _I/O	AK2	GND	AL10	I/O
AH27	HDC_I/O	AK3	I/O	AL11	VCC
AH28	M0	AK4	I/O	AL12	I/O
AH29	M1	AK5	I/O	AL13	I/O
AH30	I/O	AK6	I/O	AL14	GND
AH31	I/O	AK7	I/O	AL15	I/O
AJ1	GND	AK8	I/O	AL16	I/O
AJ2	D7_I/O	AK9	I/O	AL17	I/O
AJ3	VCC	AK10	I/O	AL18	GND
AJ4	BUFGS_BR_	AK11	I/O	AL19	I/O
	GCK4_I/O	AK12	I/O	AL20	I/O
AJ5	I/O	AK13	I/O	AL21	VCC
AJ6	I/O	AK14	I/O	AL22	I/O
AJ7	I/O	AK15	I/O	AL23	GND
AJ8	I/O	AK16	<del>BB</del> _I/O	AL24	I/O
AJ9	I/O	AK17	I/O	AL25	GND
AJ10	I/O	AK18	I/O	AL26	I/O
AJ11	I/O	AK19	I/O	AL27	I/O
AJ12	I/O	AK20	I/O	AL28	I/O
AJ13	I/O	AK21	I/O	AL29	GND
AJ14	I/O	AK22	I/O	AL30	GND
AJ15	I/O	AK23	I/O	AL31	VCC
AJ16	I/O	AK24	I/O		
AJ17	I/O	AK25	I/O		
AJ18	I/O	AK26	I/O		
AJ19	I/O	AK27	I/O		
AJ20	I/O	AK28	I/O		

FIGURE 2. Terminal connections - Continued.

<b>STANDARD MICROCIRCUIT DRAWING DEFENSE SUPPLY CENTER COLUMBUS COLUMBUS, OHIO 42316-5000</b>	<b>SIZE A</b>		<b>5962-98511</b>
		REVISION LEVEL	SHEET <b>31</b>

Device type	All	Device type	All	Device type	All
Case outline	T	Case outline	T	Case outline	T
Terminal number	Terminal symbol	Terminal number	Terminal symbol	Terminal number	Terminal symbol
P1	VSS	P36	I/O	P70	I/O
P2	BUFGP_TL_A16	P37	VSS	P71	I/O
	_GCK1_I/O	P38	I/O	P72	I/O
P3	A17_I/O	P39	I/O	P73	I/O
P4	I/O	P40	VCC	P74	I/O
P5	I/O	P41	I/O	P75	VSS
P6	TDI_I/O	P42	I/O	P76	I/O
P7	TCK_I/O	P43	I/O	P77	I/O
P8	I/O	P44	I/O_FCLK2	P78	I/O
P9	I/O	P45	VSS	P79	I/O
P10	I/O	P46	I/O	P80	VCC
P11	I/O	P47	I/O	P81	I/O
P12	I/O	P48	I/O	P82	I/O
P13	I/O	P49	I/O	P83	VSS
P14	VSS	P50	I/O	P84	I/O
P15	I/O_FCLK1	P51	I/O	P85	I/O
P16	I/O	P52	I/O	P86	I/O
P17	TMS_I/O	P53	I/O	P87	I/O
P18	I/O	P54	I/O	P88	I/O
P19	VCC	P55	I/O	P89	<del>I/O</del>
P20	I/O	P56	I/O	P90	VCC
P21	I/O	P57	BUFGS_BL_	P91	VSS
P22	VSS		GCK2_I/O	P92	I/O
P23	I/O	P58	M1	P93	I/O
P24	I/O	P59	VSS	P94	I/O
P25	I/O	P60	M0	P95	I/O
P26	I/O	P61	VCC	P96	I/O
P27	I/O	P62	M2	P97	I/O
P28	I/O	P63	BUFGP_BL_	P98	VSS
P29	VSS		GCK3_I/O	P99	I/O
P30	VCC	P64	HDC_I/O	P100	I/O
P31	I/O	P65	I/O	P101	VCC
P32	I/O	P66	I/O	P102	I/O
P33	I/O	P67	I/O	P103	I/O
P34	I/O	P68	<del>I/O</del>	P104	I/O
P35	I/O	P69	I/O	P105	I/O

FIGURE 2. Terminal connections - Continued.

<b>STANDARD MICROCIRCUIT DRAWING DEFENSE SUPPLY CENTER COLUMBUS COLUMBUS, OHIO 42316-5000</b>	<b>SIZE A</b>		<b>5962-98511</b>
		REVISION LEVEL	SHEET <b>32</b>



Device type	All	Device type	All	Device type	All
Case outline	T	Case outline	T	Case outline	T
Terminal number	Terminal symbol	Terminal number	Terminal symbol	Terminal number	Terminal symbol
P106	VSS	P151	VSS	P195	I/O
P107	I/O	P152	D3_I/O	P196	VSS
P108	I/O	P153	<del>RS</del> _I/O	P197	I/O
P109	I/O	P154	I/O	P198	I/O
P110	I/O	P155	I/O	P199	I/O
P111	I/O	P156	I/O	P200	I/O
P112	I/O	P157	I/O	P201	VCC
P113	I/O	P158	VSS	P202	A4_I/O
P114	I/O	P159	D2_I/O	P203	A5_I/O
P115	I/O	P160	I/O	P204	GND
P116	I/O	P161	VCC	P205	I/O
P117	I/O	P162	I/O	P206	I/O
P118	BUFGS_BR_GC	P163	I/O_FCLK4	P207	A21_I/O
	K4_I/O	P164	I/O	P208	A20_I/O
P119	VSS	P165	I/O	P209	A6_I/O
P120	DONE	P166	VSS	P210	A7_I/O
P121	VCC	P167	I/O	P211	VSS
P122	<del>BR06</del>	P168	I/O	P212	VCC
P123	D7_I/O	P169	I/O	P213	A8_I/O
P124	BUFGP_BR_	P170	I/O	P214	A9_I/O
	GCK5_I/O	P171	I/O	P215	A19_I/O
P125	I/O	P172	I/O	P216	A18_I/O
P126	I/O	P173	D1_I/O	P217	I/O
P127	I/O	P174	RDY_ <del>BSX</del>	P218	I/O
P128	I/O		<del>RC&amp;K</del> _I/O	P219	GND
P129	D6_I/O	P175	I/O	P220	A10_I/O
P130	I/O	P176	I/O	P221	A11_I/O
P131	I/O	P177	D0_DIN_I/O	P222	VCC
P132	I/O	P178	BUFGS_TR_	P223	I/O
P133	I/O		GCK6_DOUT_I/O	P224	I/O
P134	I/O	P179	CCLK	P225	I/O
P135	VSS	P180	VCC	P226	I/O
P136	I/O	P181	TDO	P227	VSS
P137	I/O	P182	VSS	P228	I/O
P138	I/O_FCLK3	P183	A0_ <del>WS</del> _I/O	P229	I/O
P139	I/O	P184	BUFGP_TR_	P230	I/O
P140	VCC		GCK7_A1_I/O	P231	I/O
P141	D5_I/O	P185	I/O	P232	A12_I/O
P142	<del>CS0</del> _I/O	P186	I/O	P233	A13_I/O
P143	VSS	P187	CSI_A2_I/O	P234	I/O
P144	I/O	P188	A3_I/O	P235	I/O
P145	I/O	P189	I/O	P236	I/O
P146	I/O	P190	I/O	P237	I/O
P147	I/O	P191	I/O	P238	A14_I/O
P148	D4_I/O	P192	I/O	P239	BUFGS_TL_
P149	I/O	P193	I/O		GCK8_A15_I/O
P150	VCC	P194	I/O	P240	VCC

FIGURE 2. Terminal connections - Continued.

<b>STANDARD MICROCIRCUIT DRAWING DEFENSE SUPPLY CENTER COLUMBUS COLUMBUS, OHIO 42316-5000</b>	<b>SIZE A</b>		<b>5962-98511</b>
		REVISION LEVEL	SHEET <b>33</b>

Simplified block diagram of CLB

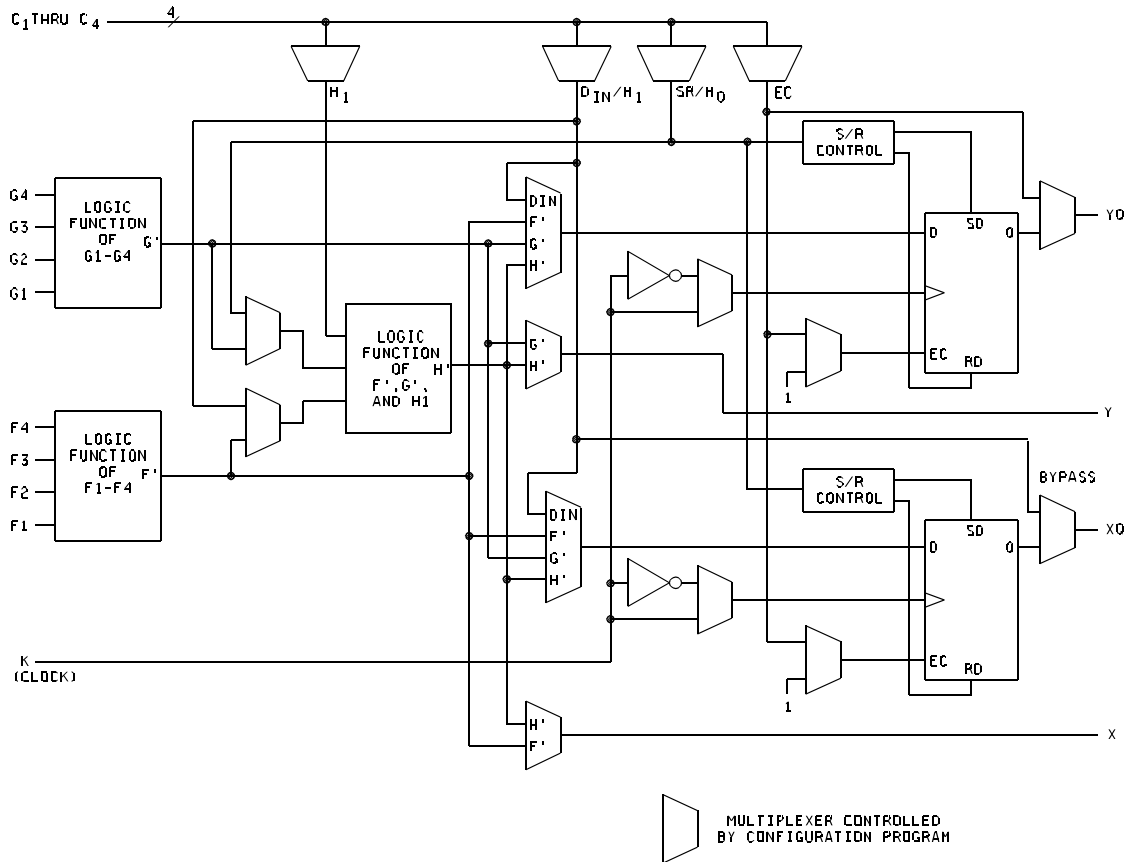

Note: The CLB storage elements can also be configured as latches. The two latches have common clock (CK) and clock enable (EC) inputs. (RAM and Carry logic functions not shown)

FIGURE 3. Logic block diagrams.

<b>STANDARD MICROCIRCUIT DRAWING DEFENSE SUPPLY CENTER COLUMBUS COLUMBUS, OHIO 42316-5000</b>	<b>SIZE A</b>		<b>5962-98511</b>
		REVISION LEVEL	SHEET <b>34</b>

### Fast Carry Logic

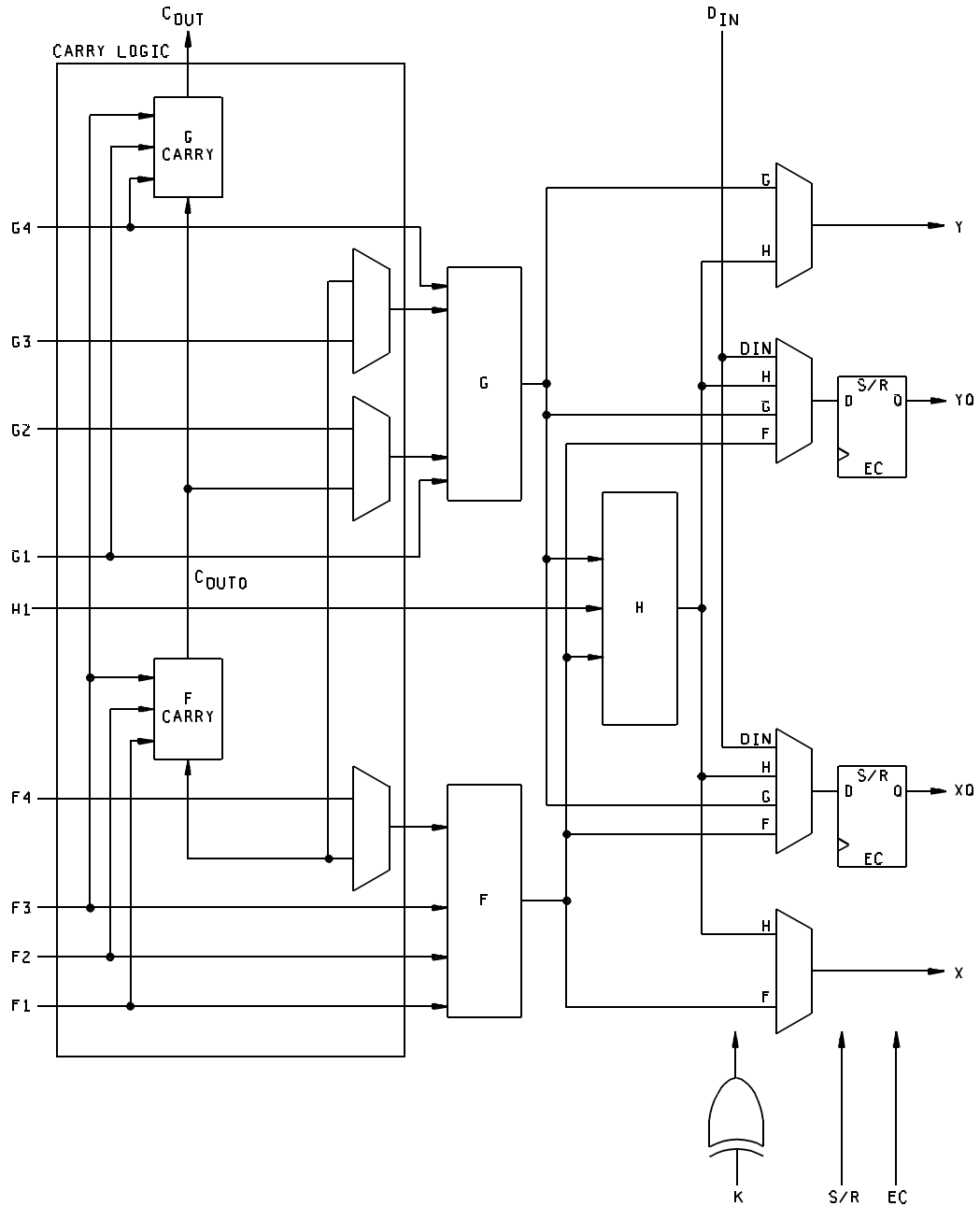

FIGURE 3. Logic block diagrams - Continued.

<b>STANDARD MICROCIRCUIT DRAWING DEFENSE SUPPLY CENTER COLUMBUS COLUMBUS, OHIO 42316-5000</b>	<b>SIZE A</b>		<b>5962-98511</b>
		REVISION LEVEL	SHEET <b>35</b>

Simplified block diagram of IOB

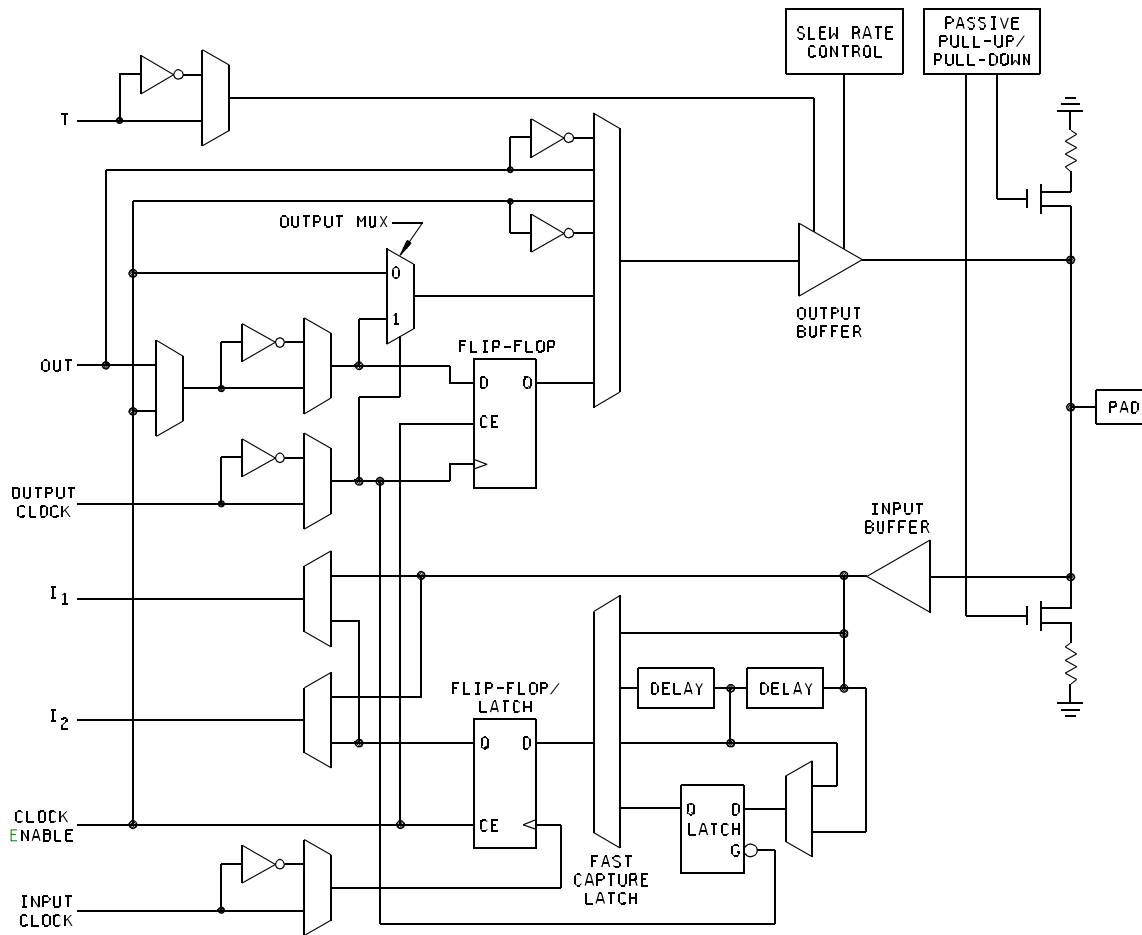

FIGURE 3. Logic block diagrams - Continued.

STANDARD  
MICROCIRCUIT DRAWING  
DEFENSE SUPPLY CENTER COLUMBUS  
COLUMBUS, OHIO 42316-5000

SIZE  
A

5962-98511

REVISION LEVEL

SHEET

36

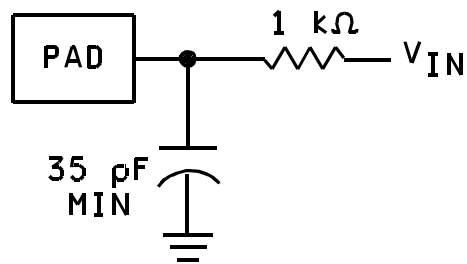

CIRCUIT A

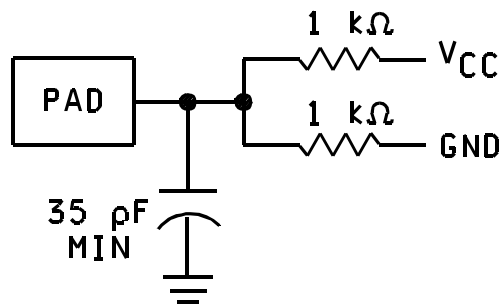

CIRCUIT B

FIGURE 4. Load circuits.

<b>STANDARD MICROCIRCUIT DRAWING DEFENSE SUPPLY CENTER COLUMBUS COLUMBUS, OHIO 42316-5000</b>	<b>SIZE A</b>		<b>5962-98511</b>
		REVISION LEVEL	SHEET <b>37</b>

4.3 Qualification inspection for device classes N, Q, and V. Qualification inspection for device classes N, Q, and V shall be in accordance with MIL-PRF-38535 and the device manufacturers QM plan. Inspections to be performed shall be those specified in MIL-PRF-38535 and herein for groups A, B, C, D, and E inspections (see 4.4.1 through 4.4.4).

4.4 Conformance inspection. Technology conformance inspection for classes N, Q, and V shall be in accordance with MIL-PRF-38535 including groups A, B, C, D, and E inspections and as specified herein except where option 2 of MIL-PRF-38535 permits alternate in-line control testing. Quality conformance inspection for device class M shall be in accordance with MIL-PRF-38535, appendix A and as specified herein. Inspections to be performed for device class M shall be those specified in method 5005 of MIL-STD-883 and herein for groups A, B, C, D, and E inspections (see 4.4.1 through 4.4.4).

4.4.1 Group A inspection.

- a. Tests shall be as specified in table IIA herein.
- b. Subgroups 5 and 6 of table I of method 5005 of MIL-STD-883 shall be omitted.
- c. For device class M, subgroups 7 and 8 tests shall be sufficient to verify the truth table. For device classes N, Q, and V, subgroups 7 and 8 shall include verifying the functionality of the device; these tests shall have been fault graded in accordance with MIL-STD-883, test method 5012 (see 1.5 herein).
- d. O/V (latch-up) tests shall be measured only for initial qualification and after any design or process changes which may affect the performance of the device. For device class M, procedures and circuits shall be maintained under document revision level control by the manufacturer and shall be made available to the preparing activity or acquiring activity upon request. For device classes N, Q, and V, the procedures and circuits shall be under the control of the device manufacturer's TRB in accordance with MIL-PRF-38535 and shall be made available to the preparing activity or acquiring activity upon request. Testing shall be on all pins, on five devices with zero failures. Latch-up test shall be considered destructive. Information contained in JEDEC Standard number 17 may be used for reference.
- e. Subgroup 4 ( $C_{IN}$  and  $C_{OUT}$  measurements) shall be measured only for initial qualification and after any process or design changes which may affect input or output capacitance. Capacitance shall be measured between the designated terminal and GND at a frequency of 1 MHz. Sample size is 5 devices with no failures, and all input and output terminals tested.
  - (1) The following shall apply to device class N only. Sample size is five devices with no failures. For  $C_{IN}$  and  $C_{OUT}$  a device manufacturer may qualify devices by functional groups. A specific functional group shall be composed of function types, that by design, will yield the same capacitance values when tested in accordance with table I herein. The device manufacturer shall set a functional group limit for the  $C_{IN}$  and  $C_{OUT}$  tests. The device manufacturer may then test one device function from a functional group to the limits and conditions specified herein. All other device functions in that particular functional group shall be guaranteed, if not tested, to the limits and conditions specified in table I herein. The device manufacturer shall submit to DSCC-VA the device functions listed in each functional group and the test results for each device tested.

4.4.2 Group C inspection. The group C inspection end-point electrical parameters shall be as specified in table IIA herein.

4.4.2.1 Additional criteria for device class M. Steady-state life test conditions, method 1005 of MIL-STD-883:

- a. Test condition A or D. The test circuit shall be maintained by the manufacturer under document revision level control and shall be made available to the preparing or acquiring activity upon request. The test circuit shall specify the inputs, outputs, biases, and power dissipation, as applicable, in accordance with the intent specified in test method 1005.
- b.  $T_A = +125EC$ , minimum.
- c. Test duration: 1,000 hours, except as permitted by method 1005 of MIL-STD-883.

4.4.2.2 Additional criteria for device classes N, Q and V. The steady-state life test duration, test condition and test temperature, or approved alternatives shall be as specified in the device manufacturer's QM plan in accordance with MIL-PRF-38535. The test circuit shall be maintained under document revision level control by the device manufacturer's TRB, in accordance with MIL-PRF-38535, and shall be made available to the acquiring or preparing activity upon request. The test circuit shall specify the inputs, outputs, biases, and power dissipation, as applicable, in accordance with the intent specified in test method 1005.

<b>STANDARD MICROCIRCUIT DRAWING DEFENSE SUPPLY CENTER COLUMBUS COLUMBUS, OHIO 42316-5000</b>	<b>SIZE A</b>		<b>5962-98511</b>
		REVISION LEVEL	SHEET <b>38</b>

TABLE IIA. Electrical test requirements. 1/ 2/ 3/ 4/ 5/ 6/ 7/

Line no.	Test requirements	Subgroups (in accordance with MIL-STD-883, method 5005, table I)	Subgroups (in accordance with MIL-PRF-38535, table III)		
		Device class M	Device class N	Device class Q	Device class V
1	Interim electrical parameters (see 4.2)				1, 7, 9
2	Static burn-in I and II (method 1015)	Required	Not Required	Required	Required
3	Same as line 1				1*, 7* )
4	Dynamic burn-in (method 1015)	Not Required	Not Required	Not Required	Required
5	Same as line 1				1*, 7* )
6	Final electrical parameters	1*, 2, 3, 7*, 8A, 8B, 9, 10, 11	2, 8A, 10	1*, 2, 3, 7*, 8A, 8B, 9, 10, 11	1*, 2, 3, 7*, 8A, 8B, 9, 10, 11
7	Group A test parameters	1, 2, 3, 4**, 7, 8A, 8B, 9, 10, 11	2, 8A, 10	1, 2, 3, 4**, 7, 8A, 8B, 9, 10, 11	1, 2, 3, 4**, 7, 8A, 8B, 9, 10, 11
8	Group C end-point electrical parameters	2, 3, 7, 8A, 8B	1, 2, 3, 7, 8A, 8B	1, 2, 3, 7, 8A, 8B	1, 2, 3, 7, 8A, 8B, 9, 10, 11 )
9	Group D end-point electrical parameters	2, 3, 8A, 8B		2, 3, 8A, 8B	2, 3, 8A, 8B
10	Group E end-point electrical parameters	1, 7, 9		1, 7, 9	1, 7, 9

- 1/ Blank spaces indicate tests are not applicable.
- 2/ Any or all subgroups may be combined when using high-speed testers.
- 3/ Subgroups 7 and 8 functional tests shall verify the truth table.
- 4/ \* indicates PDA applies to subgroup 1 and 7.
- 5/ \*\* see 4.4.1e.
- 6/ ) indicates delta limit (see table IIB) shall be required where specified, and the delta values shall be computed with reference to the previous interim electrical parameters (see line 1).
- 7/ See 4.4.1d.

TABLE IIB Delta limits at +25

Parameter 1/	Device types
	All
ICCO standby	± 1 mA of specified limit in table I.
IL	± 1 FA of specified limit in table I.

- 1/ The above parameter shall be recorded before and after the required burn-in and life tests to determine the delta.

<b>STANDARD MICROCIRCUIT DRAWING DEFENSE SUPPLY CENTER COLUMBUS COLUMBUS, OHIO 42316-5000</b>	<b>SIZE A</b>		<b>5962-98511</b>
		REVISION LEVEL	SHEET <b>39</b>

4.4.3 Group D inspection. The group D inspection end-point electrical parameters shall be as specified in table IIA herein.

4.4.4 Group E inspection. Group E inspection is required only for parts intended to be marked as radiation hardness assured (see 3.5 herein).

- a. End-point electrical parameters shall be as specified in table IIA herein.
- b. For device classes N, Q, and V, the devices or test vehicle shall be subjected to radiation hardness assured tests as specified in MIL-PRF-38535 for the RHA level being tested. For device class M, the devices shall be subjected to radiation hardness assured tests as specified in MIL-PRF-38535, appendix A for the RHA level being tested. All device classes must meet the postirradiation end-point electrical parameter limits as defined in table I at  $T_A = +25EC \pm 5EC$ , after exposure, to the subgroups specified in table IIA herein.
- c. When specified in the purchase order or contract, a copy of the RHA delta limits shall be supplied.

4.5 Delta measurements for device class V. Delta measurements, as specified in table IIA, shall be made and recorded before and after the required burn-in screens and steady-state life tests to determine delta compliance. The electrical parameters to be measured, with associated delta limits are listed in table IIB. The device manufacturer may, at his option, either perform delta measurements or within 24 hours after burn-in perform final electrical parameter tests, subgroups 1, 7, and 9.

5. PACKAGING

5.1 Packaging requirements. The requirements for packaging shall be in accordance with MIL-PRF-38535 for device classes N, Q, and V or MIL-PRF-38535, appendix A for device class M.

6. NOTES

6.1 Intended use. Microcircuits conforming to this drawing are intended for use for Government microcircuit applications (original equipment), design applications, and logistics purposes.

6.1.1 Replaceability. Microcircuits covered by this drawing will replace the same generic device covered by a contractor-prepared specification or drawing.

6.1.2 Substitutability. Device class Q devices will replace device class M devices.

6.2 Configuration control of SMD's. All proposed changes to existing SMD's will be coordinated with the users of record for the individual documents. This coordination will be accomplished in accordance with MIL-STD-973 using DD Form 1692, Engineering Change Proposal.

6.3 Record of users. Military and industrial users shall inform Defense Supply Center Columbus when a system application requires configuration control and which SMD's are applicable to that system. DSCC will maintain a record of users and this list will be used for coordination and distribution of changes to the drawings. Users of drawings covering microelectronic devices (FSC 5962) should contact DSCC-VA, telephone (614) 692-0525.

6.4 Comments. Comments on this drawing should be directed to DSCC-VA, Columbus, Ohio 43216-5000, or telephone (614) 692-0674.

6.5 Abbreviations, symbols, and definitions. The abbreviations, symbols, and definitions used herein are defined in MIL-PRF-38535, MIL-HDBK-1331.

V <sub>CC</sub>	-----	SUPPLY VOLTAGE (V).
GND	-----	GROUND
CCLK	-----	CONFIGURATION CLOCK
DONE	-----	DONE
PROGRAM	-----	PROGRAM
RCLK	-----	READ CLOCK.
M0	-----	MODE 0
M1	-----	MODE 1
M2	-----	MODE 2

<b>STANDARD MICROCIRCUIT DRAWING DEFENSE SUPPLY CENTER COLUMBUS COLUMBUS, OHIO 42316-5000</b>	<b>SIZE A</b>		<b>5962-98511</b>
		REVISION LEVEL	SHEET <b>40</b>



6.5 Abbreviations, symbols, and definitions - Continued.

TDO	-----	TEST DATA OUTPUT
TDI	-----	TEST DATA IN
TCK	-----	TEST CLOCK
TMS	-----	TEST MODE SELECT
HDC	-----	HIGH DURING CONFIGURATION
LDC	-----	LOW DURING CONFIGURATION
RTRIG	-----	READ TRIGGER.
INIT	-----	INIT
GCK1-GCK8	-----	GLOBALLow-Skew buffer
CS0	-----	CHIP SELECT, WRITE
CS1	-----	CHIP SELECT, WRITE
WS	-----	WRITE STROBE
RS	-----	READ STROBE
A0-A21	-----	ADDRESS
D0-D7	-----	DATA
DIN	-----	DATA INPUT
DOUT	-----	DATA OUTPUT
I/O	-----	INPUT/OUTPUT
RDY/BUSY	-----	During peripheral parallel mode configuration, this pin indicates when the chip is ready for another byte of data to be written into it. After configuration is complete, this pin becomes a user programmed I/O pin.

6.5.1 Timing limits. The table of timing values shows either a minimum or a maximum limit for each parameter. Input requirements are specified from the external system point of view. Thus, address setup time is shown as a minimum since the system must supply at least that much time ( even though most devices do not require it ). On the other hand, responses from the memory are specified from the device point of view. Thus, the access time is shown as a maximum since the device never provides data later than that time.

6.6 Sources of supply.

6.6.1 Sources of supply for device classes N, Q, and V. Sources of supply for device classes N, Q, and V are listed in QML-38535. The vendors listed in QML-38535 have submitted a certificate of compliance (see 3.6 herein) to DSCC-VA and have agreed to this drawing.

6.6.2 Approved sources of supply for device class M. Approved sources of supply for class M are listed in MIL-HDBK-103. The vendors listed in MIL-HDBK-103 have agreed to this drawing and a certificate of compliance (see 3.6 herein) has been submitted to and accepted by DSCC-VA.

6.7 Additional operating data.

- a. Power on delay is  $2^{14}$  cycles from the non-master mode. This provides 11 to 33 ms of wait time.
- b. Power on delay is  $2^{16}$  cycles for the master mode. This provides 43 to 130 ms of wait time.
- c. Clear is 375 cycles  $\pm$ 25 cycles and may take as long as 250 to 750  $\mu$ s.
- d. During normal power up,  $V_{CC}$  must rise from 2.0 V to  $V_{CC}$  minimum in less than 10 ms. If this does not occur, configuration must be delayed by using RESET.

<b>STANDARD MICROCIRCUIT DRAWING DEFENSE SUPPLY CENTER COLUMBUS COLUMBUS, OHIO 42316-5000</b>	<b>SIZE A</b>		<b>5962-98511</b>
		REVISION LEVEL	SHEET <b>41</b>

STANDARD MICROCIRCUIT DRAWING SOURCE APPROVAL BULLETIN

DATE: 98-11-23

Approved sources of supply for SMD 5962-98511 are listed below for immediate acquisition only and shall be added to QML-38535 and MIL-HDBK-103 during the next revisions. QML-38535 and MIL-HDBK-103 will be revised to include the addition or deletion of sources. The vendors listed below have agreed to this drawing and a certificate of compliance has been submitted to and accepted by DSCC-VA. This bulletin is superseded by the next dated revisions of QML-38535 and MIL-HDBK-103.

Standard microcircuit drawing PIN <u>1/</u>	Vendor CAGE number	Vendor similar PIN <u>2/</u>
5962-9851101QXC	68994	XQ4062XL-3BPG475
5962-9851101QYC	68994	XQ4062XL-3BCB228
5962-9851101QZC	68994	XQ4062XL-3BCB228
5962-9851101NUA	68994	XQ4062XL-3NBG432
5962-9851101NTB	68994	XQ4062XL-3NHQ240

- 1/ The lead finish shown for each PIN representing a hermetic package is the most readily available from the manufacturer listed for that part. If the desired lead finish is not listed contact the vendor to determine its availability.
- 2/ Caution. Do not use this number for item acquisition. Items acquired to this number may not satisfy the performance requirements of this drawing.

Vendor CAGE  
number

68994

Vendor name  
and address

Xilinx, Incorporated  
2100 Logic Drive  
San Jose, CA 95124

The information contained herein is disseminated for convenience only and the Government assumes no liability whatsoever for any inaccuracies in this information bulletin.